

# MAP READING AND NAVIGATION





ATTORNEY-  
GENERAL'S  
DEPARTMENT

**Emergency Management Australia is a Division  
of the Attorney-General's Department**

**PART IV**  
**Skills for Emergency Services Personnel**

**Manual 36**

# **MAP READING AND NAVIGATION**

**Second Edition**



EMERGENCY MANAGEMENT AUSTRALIA



**Australian Government**  

---

**Attorney-General's Department**  
**Emergency Management Australia**

**Copyright**

Permission to use the document and related graphics is granted provided that (1) the below copyright notice appears in all copies and that both the copyright notice and this permission notice appear, and (2) use of document and related graphics is for educational, informational and non-commercial or personal use only.

In all cases the Commonwealth of Australia must be acknowledged as the source when reproducing or quoting any part of this publication. Examples and quotations from other sources have been attributed to the original publication whenever possible and are believed to fall within fair use provisions, but these portions retain their copyright protection and must not be used without attribution.

Enquiries related to copyright should be addressed to:

The Director General  
Emergency Management Australia  
P0 BOX 1020  
Dickson ACT 2602

Or telephone (02) 6256 4600 or fax (02) 6256 4653 or email [ema@ema.gov.au](mailto:ema@ema.gov.au)

Any rights not expressly granted herein are reserved.

**Disclaimer**

This publication is presented by Emergency Management Australia for the purpose of disseminating emergency management information free of charge to individuals who provide professional training and supervision to members of professional organisations in the field of emergency management. Professional organisations include but are not limited to, professional fire fighters, trained emergency services volunteers, and members of State/Territory police and rescue organisations whose members have training and basic competencies in emergency management services.

The information in this publication is not intended to be used by the general public or untrained persons, and is not a substitute for professional advice and /or training. Untrained persons should not use this publication unless a trained and qualified emergency management professional supervises them and/or their training in the subjects listed in the publication.

Emergency Management Australia in consultation with emergency management professionals and subject matter experts exercises care in the compilation and drafting of this publication, however, the document and related graphics could include technical inaccuracies or typographical errors and the information provided may not be appropriate to all situations. In no event shall the Commonwealth of Australia (acting through Emergency Management Australia) be liable for any damages whatsoever, whether in an action of contract, negligence or other tortious action, arising out of or in connection with the sue of or reliance on any of the information presented in this publication.

Emergency Management Australia periodically updates the information in this publication. Before using this publication please check with the Training Officer in the State Emergency Services organisation in your State/Territory to ensure that this edition is the most recent and updated version of the publication."

© Commonwealth of Australia 2001

First published 1993

Amendment 1 1997

Second edition 2001

ISBN 0 642 47686 1

Edited and published by Emergency Management Australia

Reprinted by National Capital Printing, Canberra Feb 2003

# THE AUSTRALIAN EMERGENCY MANUALS SERIES

The first publication in the original AEM Series of mainly skills reference manuals was produced in 1989. In August 1996, on advice from the National Emergency Management Principles and Practice Advisory Group, EMA agreed to expand the AEM Series to include a more comprehensive range of emergency management principles and practice reference publications.

The Australian Emergency Series has been developed to assist in the management and delivery of support services in a disaster context. It comprises principles, strategies and actions, compiled by practitioners with management and service delivery experience in a range of disaster events.

The series has been developed by a national consultative committee representing a range of State and Territory agencies involved in the delivery of support services and sponsored by Emergency Management Australia (EMA).

Parts I to III are provided as bound booklets to State and Territory emergency management organisations, students, community organisations, appropriate government departments for further dissemination to approved users including local government and over 70 countries around the world.

Parts IV and V (skills and training management topics) are normally only issued as training guides in loose-leaf (amendable) form to all relevant State agencies through each State and Territory Emergency Service.

## AUSTRALIAN EMERGENCY MANUALS SERIES STRUCTURE AND CONTENT

Publishing Status  
Feb 03

### PART I – THE FUNDAMENTALS

Manual 1	Emergency Management Concepts and Principles (3rd edn)	U/R
Manual 2	Australian Emergency Management Arrangements (6th edn)	A
Manual 3	Australian Emergency Management Glossary	A
Manual 4	Australian Emergency Management Terms Thesaurus	A

### PART II – APPROACHES TO EMERGENCY MANAGEMENT

#### *Volume 1 – Risk Management*

Manual 1	Emergency Risk Management – Applications Guide	A
Manual 2	Implementing Emergency Risk Management – <i>A facilitator's guide to working with Committees and Communities</i>	A

#### *Volume 2 – Mitigation Planning*

Manual 1	Planning Safer Communities	A
----------	----------------------------	---

#### *Volume 3 – Implementation of Emergency Management Plans*

Titles to be advised		P
----------------------	--	---

### PART III – EMERGENCY MANAGEMENT PRACTICE

#### *Volume 1 – Service Provision*

Manual 1	Emergency Catering	A
Manual 2	Disaster Medicine (2nd edn)	A
Manual 3	Disaster Recovery	A/R

#### *Volume 2 – Specific Issues*

Manual 1	Evacuation Planning	A
Manual 2	Safe and Healthy Mass Gatherings	A
Manual 3	Health Aspects of Chemical, Biological and Radiological Hazards	A

Manual 4	Post Disaster Survey and Assessment	A
Manual 5	Community Emergency Planning (3rd edn)	A/R
Manual	Civil Defence	D
Manual	Urban Search and Rescue (Management)	P
Manual	Lifelines	D

**Volume 3 – Guidelines**

Guide 1	Multi-Agency Incident Management	A
Guide 2	Community and Personal Support Services	A
Guide 3	Managing the Floodplain	A
Guide 4	Flood Preparedness	A
Guide 5	Flood Warning	A
Guide 6	Flood Response	A
Guide 7	Emergency Management Planning for Floods Affected by Dams	A
Guide 8	Reducing the Community Impact of Landslides	A
Guide 9	Psychological Services: Emergency Managers' Guide	D
Guide 10	Psychological Services: Mental Health Practitioners' Guide	D
Guide 11	Disaster Loss Assessment Guidelines	A
Guide 12	Economic and Financial Aspects of Disaster Recovery	A
Guide	Community Development	D
Guide	Gathering Community Information	D
Guide	Disaster Victim Identification	D

**PART IV – SKILLS FOR EMERGENCY SERVICES PERSONNEL**

Manual 1	Storm Damage Operations (2nd edn)	A
Manual 2	Operations Centre Management	A
Manual 3	Leadership	A
Manual 4	Land Search Operations (2nd edn – Amdt 1)	A
Manual 5	Road Accident Rescue (2nd edn)	A
Manual 6	General Rescue (4th edn – formerly Disaster Rescue)	A
Manual 7	Map Reading and Navigation (Amdt 1)	A
Manual 8	Four-Wheel-Drive Vehicle Operation (Amdt 1)	A
Manual 9	Communications (2nd edn)	A
Manual 10	Flood Rescue Boat Operation (2nd edn)	A
Manual 11	Vertical Rescue (2nd edn)	A
Manual	Structural Collapse Search and Rescue	D

**PART V – THE MANAGEMENT OF TRAINING**

Manual 1	Small Group Training Management (2nd edn)	A
Manual 2	Managing Exercises	A

Key to status: A = Available A/R = original version Available/under Review  
D = under Development; P= Planned; R = under Review/Revision  
U/R = Unavailable/under Review









## FOREWORD

The purpose of this Manual is to enable Emergency Personnel to use maps efficiently, and to provide Map Reading instructors with a National Reference. It covers basic information for use of Topographical Maps and simple navigation aids. Whilst new technology such as GPS has provided significant aids to navigation, it is important that as many as possible understand and practise the application of fundamental Map Reading and Navigation. It must be emphasised that Map Reading and Navigation, like all skills, needs to be practised. Information in this Manual can be learned in theory but requires practical application in the field to develop and maintain proficiency.

Information in this Manual has been drawn from a number of publications. The major source is the Tasmania State Emergency Service Map Reading Handbook (compiled and printed by the Tasmanian Department of Primary Industries, Water and Environment in cooperation with the Tasmanian SES) which in turn is based on mainly military source material originally compiled by the now, Australian Emergency Management Institute, Emergency Management Australia. Information has been adapted and added to, in order to form a national reference.

The manual is issued in loose-leaf form to facilitate amendment and insertion of individual State and Territory supplements.

Proposed changes to the document should be forwarded to the Director-General, Emergency Management Australia, at the address shown below, through the relevant State/Territory emergency management organisation.

Use of trade names in this Manual is not intended to be restrictive, preferential or promotional. Rather, trade names are used where descriptive clarity is required.

This publication is provided free of charge to approved Australian organisations which may obtain copies through their State/Territory Emergency Service headquarters who maintain distribution and amendment registers.

Manuals may be supplied to other Australian or overseas requesters upon payment of cost recovery charges. Consideration is given to requests from developing countries for copies without charges.

Overseas enquiries (for free copies) and all others regarding purchase of this Manual should be sent to the Director-General, Emergency Management Australia, PO Box 1020, DICKSON ACT 2602, AUSTRALIA, (facsimile: +61 (0)2 6257 7665, email: [ema@ema.gov.au](mailto:ema@ema.gov.au)).



# CONTENTS

	<b>Page</b>
Information on the Australian Emergency Manuals Series	iv
Amendment Certificate	vii
Foreword	ix
Contents	xi
	<b>Paragraph</b>
<b>CHAPTER 1 RELIABILITY AND CARE OF MAPS</b>	
GENERAL	1.1
Reliability of Maps	1.2
Care of Maps	1.3
Map Folding	1.4
<b>CHAPTER 2 MAP BORDER INFORMATION AND CONVENTIONAL SYMBOLS</b>	
BORDER/MARGINAL INFORMATION	2.1
Title	2.2
Type of Map	2.3
Edition and Sheet Number	2.4
Magnetic Variation Diagram	2.5
Grid Reference Block	2.6
Symbols Legend	2.7
Control and Production Data	2.8
Index to Adjoining Sheets	2.9
Reliability Diagram	2.10
Linear Scale	2.11
Representative Fraction	2.12
Contour Interval	2.13
CONVENTIONAL MAP SYMBOLS	2.14
Symbols Explanations	2.15
<b>CHAPTER 3 SCALE, MEASURING DISTANCE AND JUDGING DISTANCE</b>	
MAP SCALE	3.1
Expressing Map Scale	3.2
MEASURING DISTANCE ON A MAP	3.3
Methods	3.3
JUDGING DISTANCE	3.4
Methods	3.4
Conditions Affecting Apparent Distance	3.5
<b>CHAPTER 4 GRID REFERENCES</b>	
The Grid System	4.1
Grid Lines	4.2
Orientation	4.3
Grid References	4.4
Grid Squares	4.5
Position Identification	4.6
THE UNIVERSAL GRID REFERENCE SYSTEM	4.7
Universal Grid References	4.8
Reference Example	4.9
Grid Zone Junctions	4.10
ROMER SCALES	4.11
Using the Scale	4.12

<b>CHAPTER 5</b>	<b>GROUND SHAPE, GRADIENTS AND INTERVISIBILITY</b>	
	INTRODUCTION	5.1
	RELIEF	5.2
	Elements of Representation	5.2
	Methods of Showing Relief	5.3
	Contour Patterns	5.4
	REPRESENTATION OF HEIGHT	5.5
	Common Methods	5.5
	MAP READING TERMINOLOGY	5.6
	Physical Features	5.6
	GRADIENTS	5.7
	Measuring Gradients	5.9
	Calculating Distance by Pacing	5.10
	Maximum Gradient for Vehicular Use	5.11
	INTERVISIBILITY (LINE OF SIGHT)	5.12
	Obstructions	5.13
	Making a Section	5.15
<b>CHAPTER 6</b>	<b>DIRECTION</b>	
	THE COMPASS	6.1
	Cardinal Points	6.1
	The Degree System	6.2
	Bearings	6.4
	NORTH POINTS	6.7
	True North	6.8
	Magnetic North	6.9
	Grid North	6.10
	Grid and True Bearings	6.11
	PROTRACTORS	6.12
	Using a Protractor	6.14
	Plotting a Bearing	6.15
	The Douglas Protractor	6.16
	MAGNETIC VARIATION/DECLINATION	6.17
	Pole Movement	6.18
	Isogonals	6.19
	CONVERSION OF BEARINGS	6.20
	Conversion Problems	6.21
	Easterly Variation	6.22
	Westerly Variation	6.24
	Conversion Diagram	6.27
	BACK BEARINGS	6.28
<b>CHAPTER 7</b>	<b>COMPASSES</b>	
	GENERAL	7.1
	THE PRISMATIC COMPASS	7.3
	Field use in Daylight	7.4
	Setting a Prismatic Compass for Night Movement	7.5
	THE ORIENTEERING COMPASS	7.6
	Using an Orienteering Compass	7.8
	Back Bearings	7.9
	THE ELECTRONIC COMPASS	7.10
	Altering Direction to Avoid an Obstacle	7.13
	COMPASS ERRORS	7.15
	Individual Compass Error	7.16
	Local Magnetic Attraction	7.17

<b>CHAPTER 8</b>	<b>MAP ORIENTATION, POSITION FIXING AND MAP ENLARGEMENT</b>	
	MAP SETTING	8.1
	Setting by Inspection	8.2
	Setting by Compass	8.3
	POSITION FIXING BY COMPASS RESECTION	8.4
	Procedure	8.4
	RESECTION BY OVERLAY	8.5
	MAP ENLARGEMENT	8.6
	Method of Enlargement	8.7
	Adding Information	8.8
<b>CHAPTER 9</b>	<b>CROSS-COUNTRY NAVIGATION</b>	
	INTRODUCTION	9.1
	General	9.1
	NAVIGATION AIDS	9.3
	Maps	9.3
	Aerial Photography	9.4
	Compass	9.5
	Improvised Navigation by the Sun	9.6
	Direction from the Stars	9.7
	Planning	9.8
	Map Study	9.9
	Navigation Data Sheet	9.10
	MAINTAINING DIRECTION USING A COMPASS	9.11
	Preferred Method	9.12
	Checking	9.13
	Summary	9.14
	Navigation Under Special Conditions	9.15
	ACTION IF LOST	9.16
	Considerations	9.16
	Position Fixing	9.17
	Briefing Details	9.18
<b>CHAPTER 10</b>	<b>AERIAL PHOTOGRAPHY</b>	
	INTRODUCTION	10.1
	PHOTO READING AND PHOTO INTERPRETATION	10.2
	Photo Reading	10.3
	Photo Interpretation	10.4
	PHOTO-MAP COMPARISON	10.5
	Maps	10.6
	Air Photos	10.7
	Summary	10.8
	TYPES OF AERIAL PHOTOGRAPHY	10.9
	Vertical Photographs	10.10
	Oblique Photographs	10.12
	STEREOSCOPY	10.13
	Stereovision	10.14
	The Stereoscope	10.16
	Using the Stereoscope	10.17
	MOSAICS	10.18
	Types of Mosaics	10.19

**CHAPTER 11 LATITUDE, LONGITUDE SYSTEM AND  
MARINE CHARTS**

INTRODUCTION	11.1
Map Variations	11.1
Marine Navigation	11.2
UNITS OF MEASURE	11.3
Main Systems	11.3
Knots vs Kilometres Per Hour	11.4
Other Terms of Nautical Measurement	11.5
Conversion Factors	11.6
IDENTIFICATION OF LOCATIONS ON CHARTS	11.7
Meridians of Longitude	11.8
Parallels of Latitude	11.9
Degrees, Minutes and Seconds	11.10
CONVENTIONS FOR STATING POSITIONS	11.11
Use of Seconds	11.12
MEASURING DISTANCES ON CHARTS	11.13
Mercator Projection	11.14
Measuring Process	11.15
Gnomonic Projection	11.16
SUMMARY	11.17

**CHAPTER 12 GLOBAL POSITIONING SYSTEM**

THE GLOBAL POSITIONING SYSTEM	12.1
HOW GPS WORKS	12.3
WHAT A GPS CAN DO	12.4
GPS NAVIGATION	12.6
GPS PERFORMANCE AND LIMITATIONS	12.8
GRID COORDINATES	12.12
MANUFACTURERS INSTRUCTIONS	12.13

**CHAPTER 13 GEOCENTRIC DATUM OF AUSTRALIA**

GEOCENTRIC DATUM OF AUSTRALIA	13.1
BENEFITS	13.3
DIFFERENCES	13.4
IMPLICATIONS	13.5

**CHAPTER 14 GEOGRAPHIC INFORMATION SYSTEMS**

THE GEOGRAPHIC INFORMATION SYSTEM	14.1
-----------------------------------	------

**GLOSSARY**



# CHAPTER 1

---

## Reliability and Care of Maps

### GENERAL

- 1.1 Map reading and navigation, in the context of emergency services usage, is a skill which has three specific purposes. These are to:
- a. enable users to find their way about the country and to recognise features on the ground and on the map;
  - b. enable users to understand the information given on the map so that they can picture the ground and its possibilities and limitations, even though they have not seen them; and
  - c. assist in the quick and accurate transmission of information on locations of people or objects from their actual locations on the ground to maps relevant to any operation or activity.

### 1.2 RELIABILITY OF MAPS

A map is a plan of the ground, but however accurately it may have been produced, it is a plan of the ground at a certain date. If it is a long time since it was produced or revised, much may have changed. Towns grow, roads and railways are built, forests grow and are cut down. No map can be taken as being absolutely reliable except as regards the main physical features. Even they may change slowly; coast lines erode and in some places rivers tend to change their course. It is therefore very important to note the date on which the map was produced or revised and to judge its reliability accordingly.

### 1.3 CARE OF MAPS

Maps are valuable documents and they are becoming increasingly more expensive, supply is never unlimited, therefore, they must be treated with care to prevent damage. Most damage to maps occurs when the users open them full out in the open air or in moving vehicles. A slight breeze may catch them and start small tears which quickly spread. To prevent tears, maps should be folded in such a way that any part can be referred to without having to open the map full out.

#### 1.4 MAP FOLDING

The most suitable way of folding a map is in three steps as show in Figure 1-1.

Step 1 – First fold it in half with the map detail outwards.

Step 2 – Then fold across the other way, concertina fashion.

Step 3 – The number of folds depends on the size of the map.

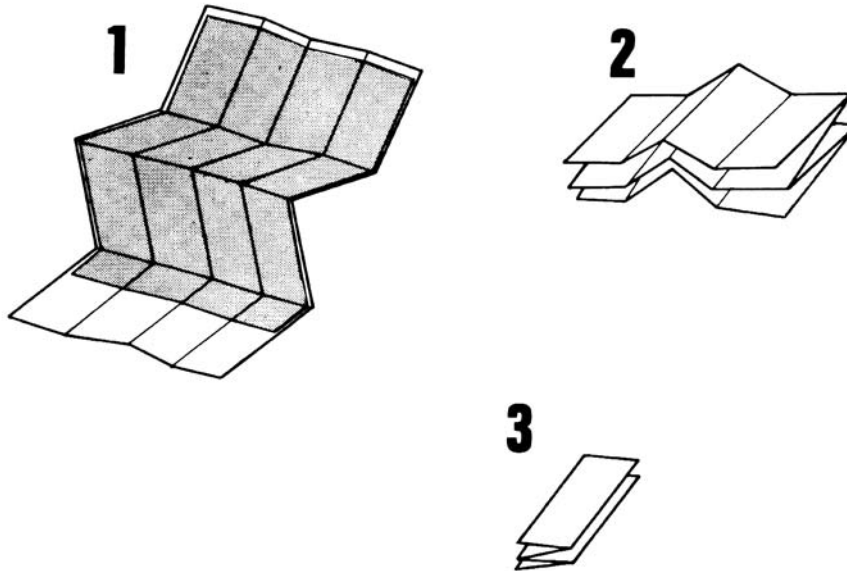

Figure 1-1: How to Fold a Map

**1.5** Once a map is folded, leave it folded when not in use. The detail at creases is bound to deteriorate but less than if the map were constantly unfolded and folded. Protect the folded map by placing it in a map case or plastic bag when not in use.

**1.6** There are many other methods used to protect a map including:

- a. covering it with clear adhesive plastic;
- b. the use of a map board with a plastic film covering;
- c. spraying it with a special protective coating; and
- d. laminating.

However, these methods are usually not recommended for field use.

# **CHAPTER 2**

---

## **Map Border Information and Conventional Symbols**

### **BORDER/MARGINAL INFORMATION**

- 2.1** Printed around the border or margin of the map is the information needed when the map is being used. This is referred to as border or marginal information. The type of information and the layout may differ slightly from one map to another. Listed below are the items that are normally part of the standard layout:
- 2.2 TITLE**  
This is shown on the top centre of the map. It may be the name of an important town, or of an area and indicates roughly the coverage of the map.
- 2.3 TYPE OF MAP**  
This is usually located on the top left beneath the Representative Fraction (RF). It describes the type of map, eg Topographical, Geological, Thematic, etc.
- 2.4 EDITION AND SHEET NUMBER**  
This information is usually located at the top right of the map and is sometimes reproduced at the bottom right of the sheet, for example sheet 9148-1-SE series R834 edition 1.
- 2.5 MAGNETIC VARIATION DIAGRAM**  
This gives the variation between Magnetic North, Grid North and True North. The annual change is also given.
- 2.6 GRID REFERENCE BLOCK**  
This describes how to calculate a grid reference.
- 2.7 SYMBOLS LEGEND**  
This is usually a series of blocks located at the bottom or side margins of the map which gives a legend of the conventional signs used together with their meanings.
- 2.8 CONTROL AND PRODUCTION DATA**  
This is usually located near the Grid Reference Block, and gives production details which include data of survey, map accuracy, and reliability.
- 2.9 INDEX TO ADJOINING SHEETS**  
This is found at the bottom of the sheet. It gives the details of adjoining maps.

**2.10 RELIABILITY DIAGRAM**

This diagram may appear on some older maps to show the extent of the map which was produced from air photographs.

**2.11 LINEAR SCALE**

This is used for measuring distance.

**2.12 REPRESENTATIVE FRACTION**

This is a method of indicating the scale of the map. Located at the top left of the map and also above the linear scale.

**2.13 CONTOUR INTERVAL**

The contour interval (the vertical distance between contour lines) is shown beneath the Linear Scale.

**CONVENTIONAL MAP SYMBOLS**

**2.14** The map maker (cartographer) tries to show the objects on the ground in the clearest possible way. These objects are not shown as they appear because they would be too small to recognise. Instead, simple symbols, referred to as Map Symbols or Conventional Signs, are used to indicate the objects. There are many map symbols used by map makers, not all of which appear on each map due to space restrictions.

2.15

**SYMBOLS EXPLANATIONS**

As a general rule the symbols used on a particular map sheet are explained in the legend. An example of the conventional signs used on maps is shown in Figure 2-1. Note that more than one symbol may be described on each line.

**SOME TYPICAL TOPOGRAPHIC MAP SYMBOLS**

Built-up area; National route marker .....	
Main city business area; Recreation reserve .....	
Road sealed surface two or more lanes; Cutting.....	
Road sealed surface one lane; Embankment .....	
Road unsealed surface two lanes; Underpass.....	
Road unsealed surface one lane; Overpass .....	
Vehicle track; Culvert .....	
Bridge road; Causeway; Bridge railway .....	
Gate; Cattle grid; Foot bridge .....	
Railway multiple track; Station; Siding .....	
Railway single track; Tunnel railway .....	
Light railway or tramway; Foot track .....	
Telephone line; Power transmission line .....	
Fence; Levee or bank .....	
Mine; Windmill; Quarry .....	
Yard; Building or shed; Church.....	
Post office; School; Hospital .....	
Police station; Fire station .....	
Trigonometrical station; Bench mark .....	
Spot elevation; Contour with value; Cliff .....	
Depression contour; Sand dunes; Sand ridges ...	
Forest dense; medium; scattered .....	
Scrub dense; medium; scattered .....	
Tropical rain forest; Pine plantation .....	
Orchard or Vineyard; Windbreak .....	
Lake perennial; Stream perennial .....	
Lake intermittent; Stream intermittent .....	
Lake mainly dry; Stream mainly dry .....	
Swamp perennial; intermittent .....	
Land subject to inundation; Ricefield .....	
Tank or small dam; Bore or well; Spring .....	
Disappearing underground; Waterholes .....	
Mangrove; Wharf; Pier; Breakwater.....	
Sand; Rock bare or awash .....	
Mud; Wreck exposed .....	
Ledge; Coastline approximate; Reef .....	

Figure 2-1: Some Typical Topographic Map Symbols



# CHAPTER 3

## Scale, Measuring Distance and Judging Distance

### MAP SCALE

3.1 The scale of a map is the relation between the horizontal distances measured of the ground and between the same two points measured on the map. The relationship is constant, in whatever direction the distances are measured.

### 3.2 EXPRESSING MAP SCALE

There are two methods of expressing the scale of a map:

- a. **Representative Fraction** – Map scale expresses the size relationship between the feature shown on a map and the same features on the earth’s surface. Scale is generally expressed as a ratio or fraction such as 1:10 000 or 1/10 000 and in this form is known as the Representative Fraction or the RF of a map. The numerator of the Representative Fraction (which is always quoted as 1) represents the map distance, and the denominator represents the ground distance. An RF of 1:100 000 therefore means that the map distance will be 1/100 000 of that actual ground distance or that a distance of 1 centimetre on the map will be 100 000 centimetres, or alternatively, 1000 metres or 1 kilometre on the ground. The scale of a map quoted as a representative fraction eg Scale 1:100 000 usually appears at the head of a map or above the scale bar.

1:10 000	surveyors, shire councils
1:25 000	recreational users eg bushwalkers, off road drivers
1:50 000	military, State Emergency Services
1:100 000	military, State Emergency Services
1:250 000	aviators

Table 3-1: Common use scales

- b. **Scale Bar or Linear Scale** – A method of measuring ground distances from a map is to use the scale bar or linear scale that is usually provided on most maps as illustrated.



Figure 3-1: Linear Scale

On a scale bar the actual distance is quoted for its equivalent map distance and a zero appears a little way along so that only the portion to the left is finely divided. The correct way to use a scale bar is to take most of the reading from the major subdivisions and then to add this to the balance of the distance measured from the finer divisions.

## MEASURING DISTANCE ON A MAP

### 3.3 METHODS

There are many ways of measuring distance on a map using dividers, a length of string, a rule, etc. Two simple methods using a strip of paper are described below:

- a. **Measuring Straight Distance** – To measure the distance in a straight line between two points on a map, lay the straight edge of a piece of paper against the two points and mark the distance on the paper. Next, lay the paper along the linear scale with the right hand mark against one of the primary divisions and the left hand mark against the secondary divisions to the left. The total distance is zero, plus the distance to the left of the zero, the distance in Figure 3-2 is 600 metres.

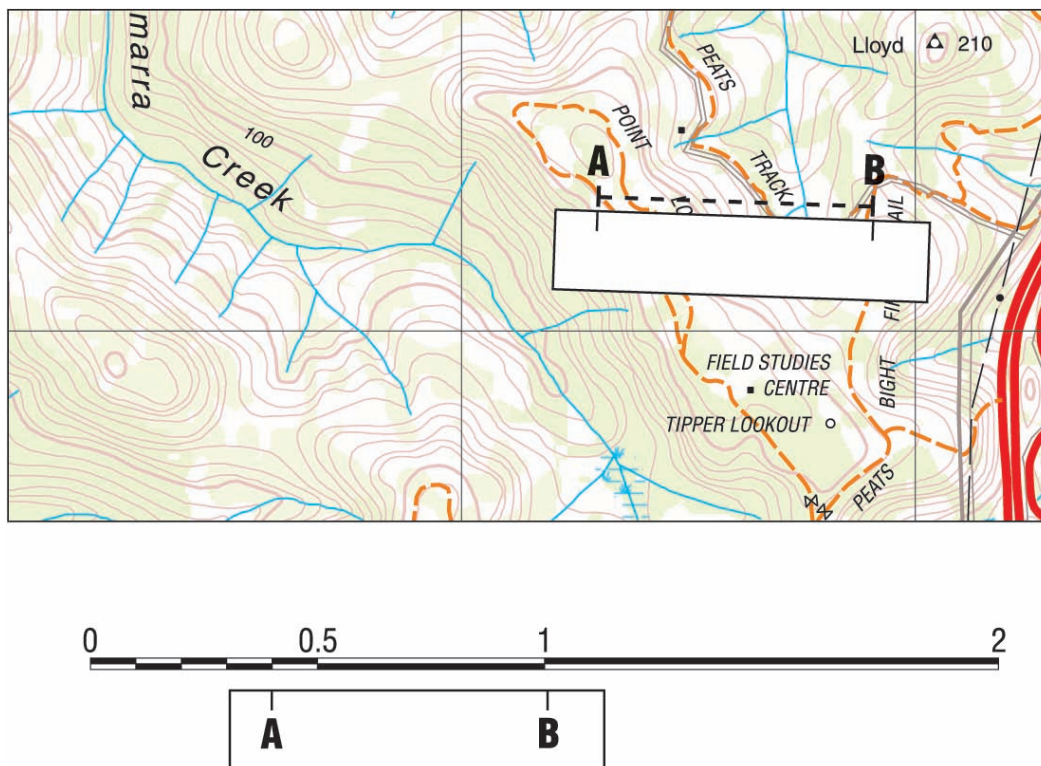

Figure 3-2: Measuring Straight Distance

- b. **Measuring Distance Along a Road** – It is often necessary to measure a distance that is not straight, eg along a road. To calculate the distance from 'A' to 'B' in Figure 3-3, consider the road as a number of straight, or nearly straight sections. Lay a piece of paper along the first section and mark it at 'A' and at the end of the straight section. Pivot the paper about the second mark until it lies along the second section. Mark the end of the second section and continue this method until 'B' is reached. The total distance by road is then recorded as a straight line on the piece of paper and can read off against the linear scale. The distance in Figure 3-3 is 680 metres.



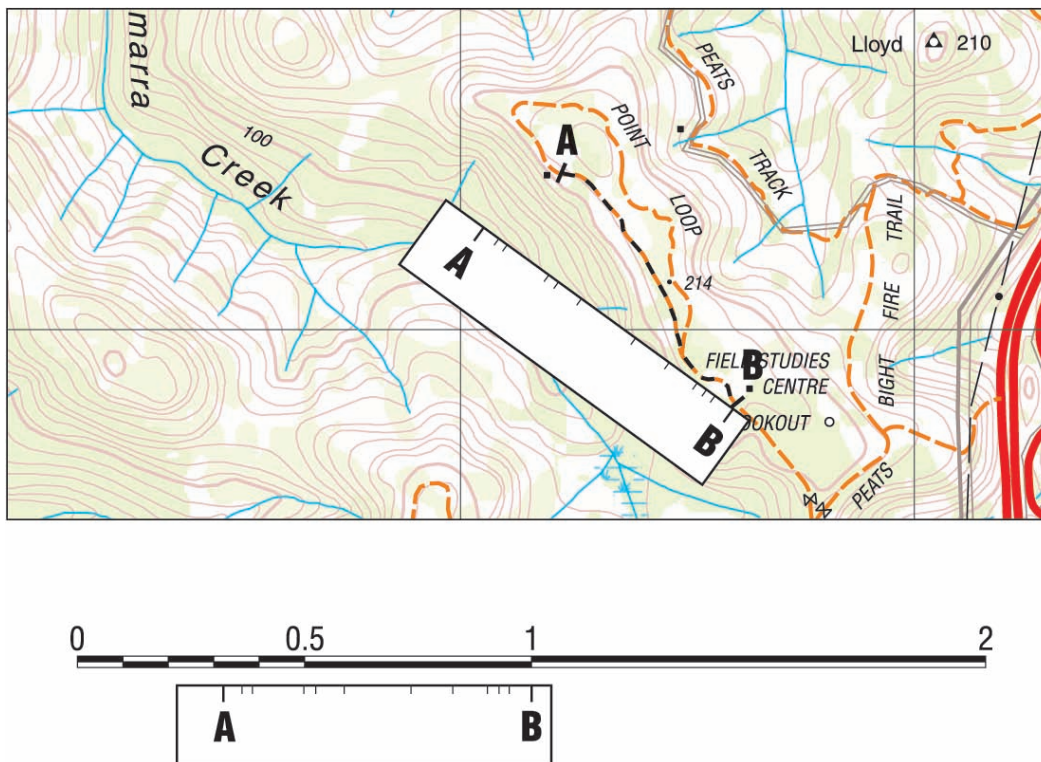

Figure 3-3: Measuring Distance Along a Road

## JUDGING DISTANCE

### 3.4 METHODS

The four most common methods of judging distance are described below:

- a. **Unit of Measure Method** – This involves taking a distance with which the viewer is familiar (eg the length of a football field or the length of a cricket pitch) as the unit and seeing how many units can be fitted in between the viewer and the object. This method is, however, of little use unless viewers can see all the ground between themselves and the object, nor is it useful for distances over 400 metres.
- b. **Appearance Method** – In this case the viewer actually judges the distance to an object by comparing it with its surroundings. It takes practice to become proficient but under certain circumstances this method could prove extremely valuable.
- c. **Bracketing Method** – The viewer decides on a minimum and maximum distance that the object is away and then takes the average between the two distances; eg it may be decided that a particular object is more than 200 metres away but less than 600 metres. Therefore the distance, in this case, is estimated to be 400 metres.
- d. **Group Average Method** – This relies on having a team on hand. The team leader asks each member to estimate the distance to the object. The average of these distances is then calculated. If team members are practised in the skill of judging distances, this method is reasonably accurate.

### **3.5 CONDITIONS AFFECTING APPARENT DISTANCE**

There are a number of conditions that can affect the accuracy of the distance being measured by the viewer. Some examples of these conditions are:

- a. Objects seem closer than they really are when:
  - (1) light is bright or the sun is shining from behind the observer;
  - (2) there is hidden ground between them and the viewer; or
  - (3) they are higher up than the viewer.
  
- b. Objects seem farther away than they really are when:
  - (1) light is poor or the sun is in the viewer's eyes;
  - (2) they are smaller than other things around them;
  - (3) the viewer is looking across a valley or down a ravine or gully;
  - (4) the viewer is lying down; or
  - (5) the object is against a dark background.

# CHAPTER 4

---

## Grid References

### 4.1 THE GRID SYSTEM

There are two systems used as a reference to any point on a map, these being the grid reference system, and the latitude and longitude system (see Chapter 11).

### 4.2 GRID LINES

Superimposed over the entire map sheet of a grided map are vertical and horizontal lines. These lines, known as Grid Lines, are numbered at each end. Every tenth line is in heavy black print and is also numbered at various places along its length. The distance between the grid lines can usually be related to the measurements on the map scale, normally equivalent to a ground distance of 1000 metres.

### 4.3 ORIENTATION

Maps are normally printed so that north is approximately at the top of the sheet. Therefore the grid lines are printed so that the one set of lines run approximately north-south and the other set of lines run approximately east-west. The position of a point within a square is thus indicated by its distance east of a north-south line and north of an east-west line.

### 4.4 GRID REFERENCES

To assist the user when giving grid references, grid lines are further defined as follows:

- a. **Eastings** – The vertical grid lines, which run from bottom to top and divide the map from west to east, are known as EASTINGS. They are numbered from west to east.
- b. **Northings** – The horizontal grid lines, which run from left to right and divide the map from south to north, are known as NORTHINGS. They are numbered from south to north.

### 4.5 GRID SQUARES

The squares which are formed where Eastings and Northings cross are known as Grid Squares. On a map they usually represent an area of 1000 m x 1000 m or 1 square kilometre.

### 4.6 POSITION IDENTIFICATION

There are three methods used to identify positions on a grided map using the grid reference system. The method used depends on the degree of accuracy required by the user and, to a large extent, the scale of the map being used. The basic principles for each method is the same and is explained below:

- a. **Four Figure Grid Reference** – This method indicates the position of one grid square only and is therefore useful when identifying major features and localities. To indicate a particular grid square, first select the Easting which

forms the left, or west boundary of that square. Next, select the Northing which forms the bottom, or south boundary of the square. The two figures for the Easting and the two figures for the Northing combined gives the four figure reference required. A four figure grid reference represents an area of 1 km x 1 km on the ground.

EXAMPLE: To give a four figure grid reference to square A in Figure 4-1.

First select the Easting which forms the west boundary of square A. In this case it is Easting 31. Next, select the Northing which forms the south boundary of square A. In this case it is Northing 86. The four figure grid reference to square A is therefore 3186.

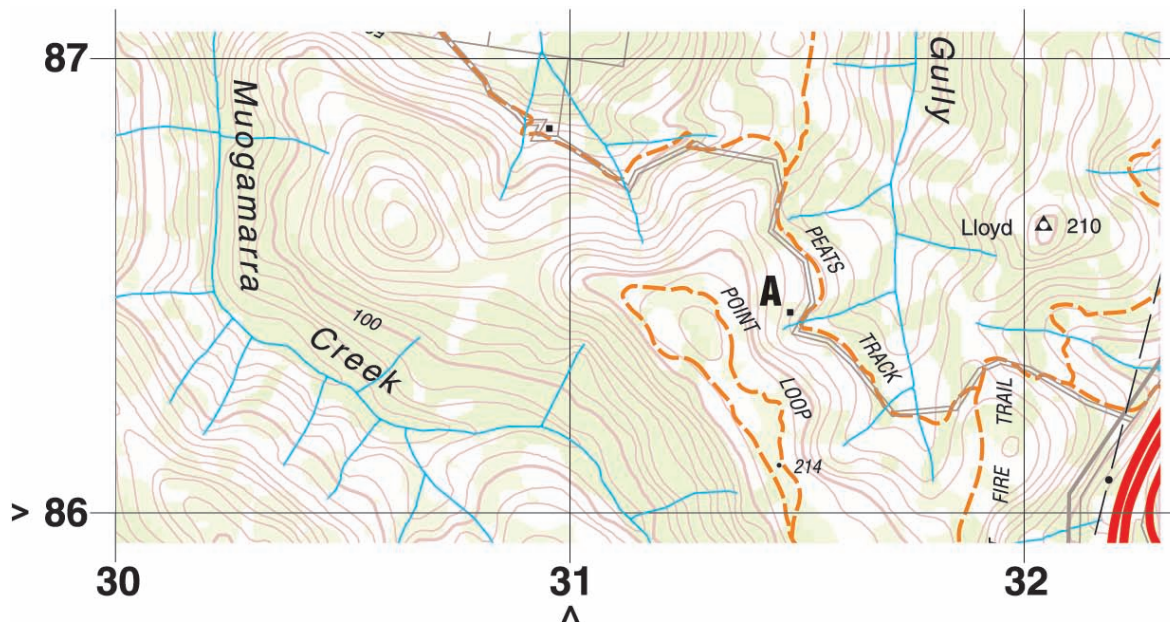

Figure 4-1: Four Figure Grid Reference

b. **Six Figure Grid Reference** – This method is much more accurate than the four figure method explained above and is used to indicate an object within a grid square. In a grid reference, the eastings are always quoted first. A six figure grid reference is derived as follows:

- (1) Read the two figure grid value at the north or south margin nearest to the left of the point and then estimate in tenths the distance from that grid line to the next one. This provides the first three figures (eastings) of the six figure grid reference.
- (2) Read the two figure grid value appearing in the left and right margins of the grid line closest below the point, and then estimate in tenths its distance from that grid line to the one immediately above it. This provides the last three figures (northings) of the six figure grid reference.
- (3) From the map below the grid reference for building 'A' is:  
 31 and 5/10 East, or 315; and  
 86 and 4/10 North, or 864.  
 Therefore the grid reference is GR315864.

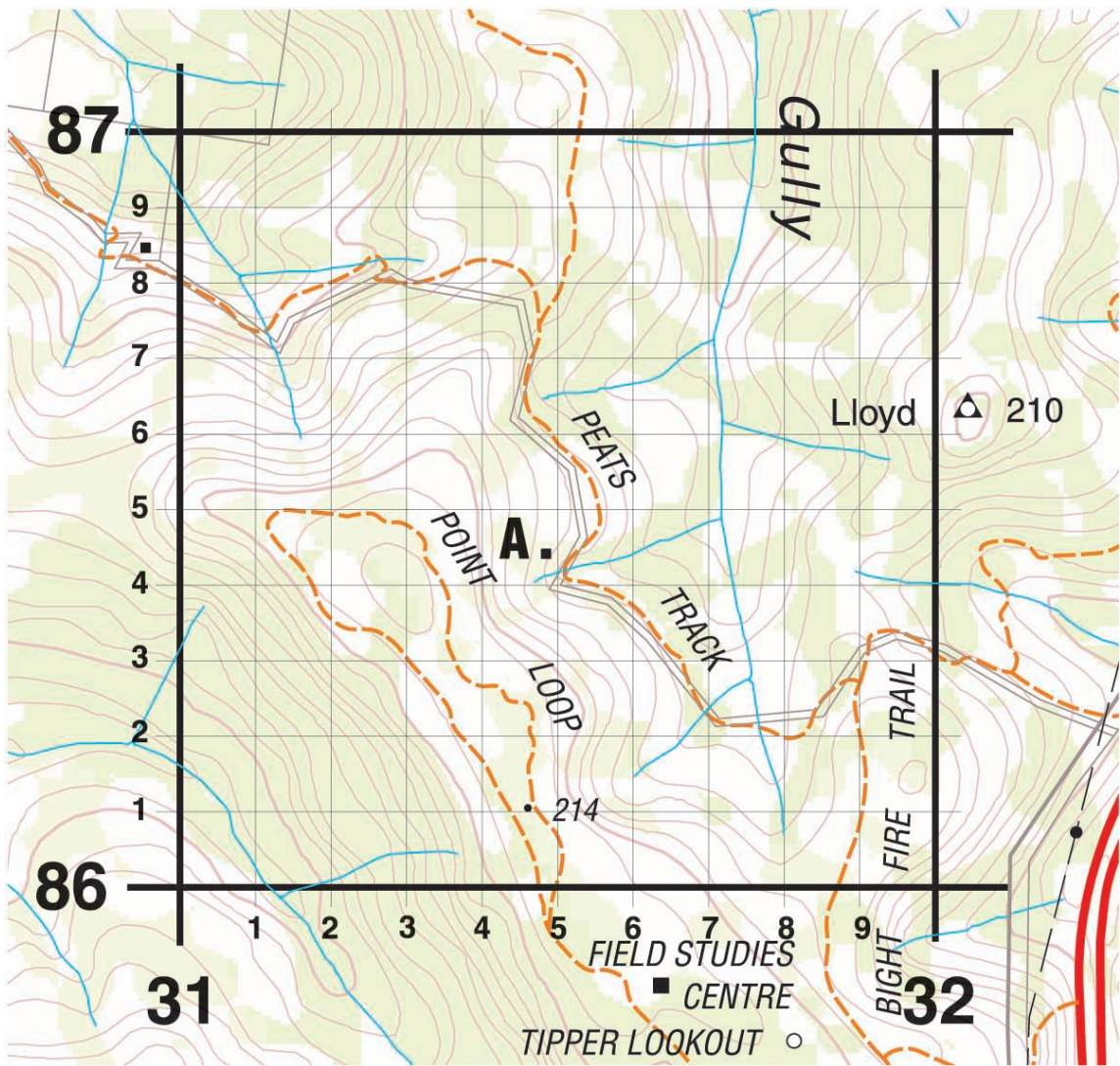

Figure 4-2: Building 'A' GR315864 Six Figure Grid Reference (Example 1)

When quoting a grid reference, the number of the map sheet from which it has been derived should also be quoted. As the number of the 1:25 000 sheet on which building 'A' falls is Cowan 9130-4N, the full reference for the position of that feature becomes: 9130-4N GR315864.

**Note:** A six figure grid reference represents an area of 100 m x 100 m on the ground.

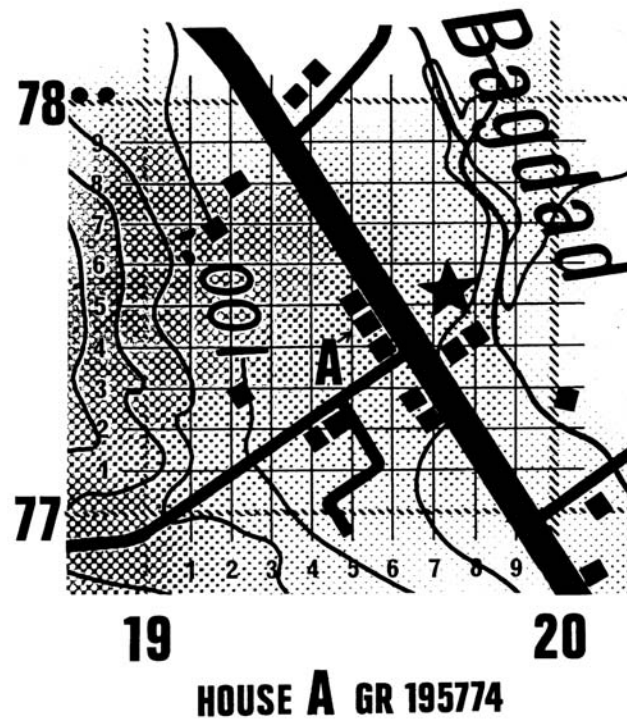

Figure 4-3: Six Figure Grid Reference (Example 2)

- c. **Eight Figure Grid Reference** – This method is most used on maps with a scale of 1:50 000 or larger. The method is similar to the six figure method explained above except that each small square is again divided into 100 still smaller squares. The result is that the Eastings are then calculated to four figures and the Northings to four, the combination being an eight figure grid reference. This method has limited practical use and therefore is rarely required. A eight figure grid reference includes an area of 10 m x 10 m on the ground.

**Notes:**

Always deal with eastings first, then northings.

When transmitting grid references over the radio or telephone in the first instance always quote the map sheet number or title.

Also when transmitting grid references always commence with the prefix 'GRID' to show that they are, in fact, grid references and nothing else.

All written grid references are preceded with the letters GR.

**THE UNIVERSAL GRID REFERENCE SYSTEM**

- 4.7 A fourth method of stating a grid reference may sometimes be required. In some parts of Australia users may find that adjoining map sheets have grid systems which have widely different numbering systems for eastings. Also it occurs that two grid systems appear on the same map sheet. This is because the universal grid zone system divides the world into squares of 100 000 metres at the equator, but not so at other latitudes because of the shape of the earth. A number of junctions of zones occur on the map of Australia. Where this occurs the problem is simply overcome by ensuring that the sheet title and number are given before the grid reference where any confusion could occur.

**4.8 UNIVERSAL GRID REFERENCES**

The method of giving a universal grid reference is explained on the bottom of most maps. A universal grid reference consists of a group of letters and numbers which indicate:

- a. grid zone designation;
- b. 100 000 m square identification; and
- c. grid coordinates (expressed to the desired accuracy).

**4.9 REFERENCE EXAMPLE**

Thus, a point may be referenced as:

- a. 49JDG locating a point within a 100 000 m square;
- b. 49JDG71 locating a point within a 10 000 m square;
- c. 49JDG7113 locating a point within a 1000 m square; or
- d. 49JDG717137 locating a point within 100 m.

**4.10 GRID ZONE JUNCTIONS**

In certain instances, a map sheet may contain more than one grid. This condition results from a junction between two grid zones within the universal grid reference system. On large scale maps, the occurrence of a junction within the sheet is rare since the sheet lines are usually laid out to coincide with junctions. On medium and small scale sheets, junctions are more prevalent than on larger scale maps owing to the greater area covered (see Figure 4-5).

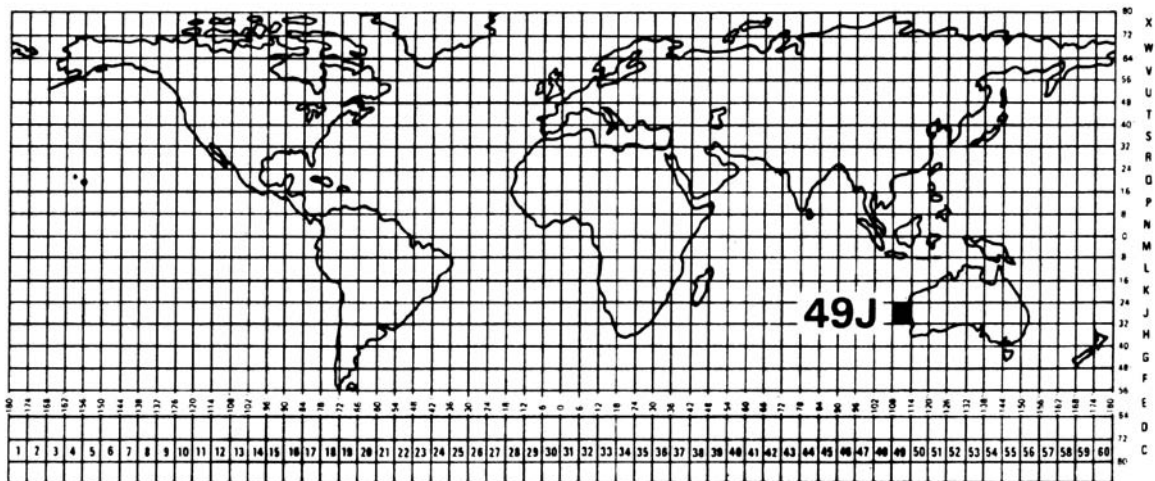

Figure 4-4: Universal Grid Zone Designation



Figure 4-5: A Grid Zone Junction



## ROMER SCALES

**4.11** A romer scale is a simple device used for accurately measuring the position of a point within a grid square instead of estimating the tenths as described in the previous paragraph.

**4.12 USING THE SCALE**

To use a romer scale place the corner against the required point on the map with the edges parallel to the grid lines. The distance east and north within the grid square can then be read off against the west and south grid lines of the square. Clearly a different romer scale is required for each scale of map.

**4.13** Romer scales for a variety of maps are sometimes engraved on protractors and also on the compass plate of some compasses. If such a romer scale is not available, one can be easily made from a piece of paper or cardboard, marking off the appropriate sub-divisions of a grid square from the secondary divisions of the linear scale on the appropriate map. The use of a romer scale is shown in Figure 4-6.

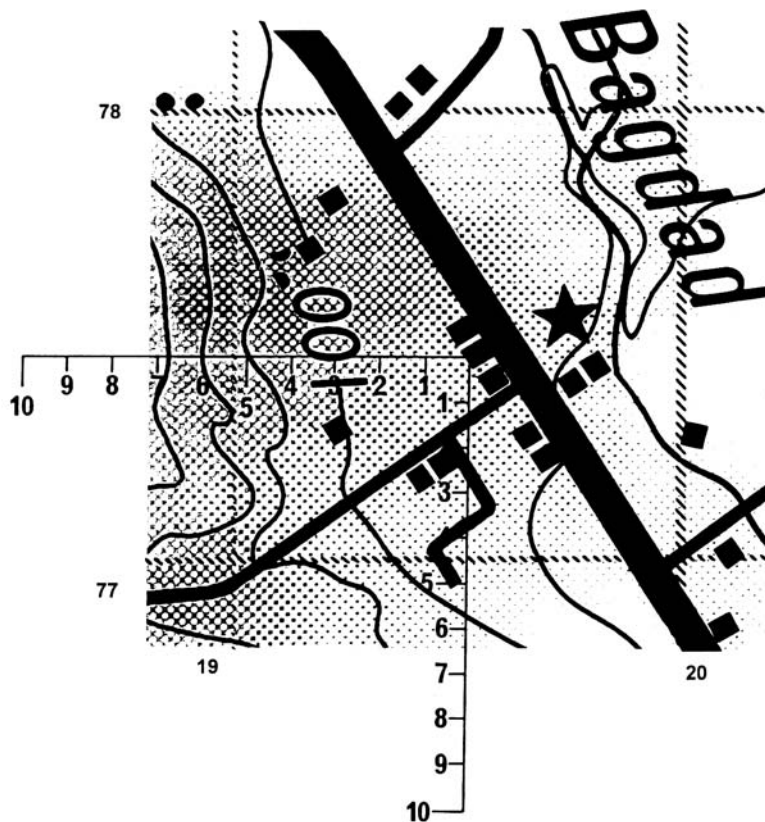

Figure 4-6: Use of a Romer Scale

When using a Romer Scale as above the grid reference for the house will be GR195774.



# CHAPTER 5

---

## Ground Shape, Gradients and Intervisibility

### INTRODUCTION

- 5.1 Maps are sometimes described as ‘pictures of the earth as seen from above’ and their purpose is to allow a person to visualise far more of their surroundings than they can see from standing on the ground. Human-made features, such as towns, roads and railways are incidents on the surface of the ground. Their details change quite rapidly. The shape of the ground (often referred to as relief) is permanent and determines the nature of the life lived on it, of the things people build on it, the position of towns and direction of communications. It is important to be able to visualise, from the map, the shape of the ground. It shows what positions may be suitable for good observation, what ground is most suitable for cross-country movement and so on.

### RELIEF

#### 5.2 ELEMENTS OF REPRESENTATION

There are two distinct elements in the representation of relief:

- a. **Height** – Representation of height is a factual matter in which variations will arise from the type, density and accuracy of information provided.
- b. **Shape** – Representation of shape may be largely artistic and the methods will vary on different maps.

#### 5.3 METHODS OF SHOWING RELIEF

Following are three common ways of showing relief on maps:

- a. **Hachures** – With this method, (Figure 5-1), rising ground is shown by fine lines drawn down lines of slope and heaviest on steepest slopes. Hachures give a good impression of the shape of the ground but are not often used now for accurate mapping because they have two great disadvantages in that:
  - (1) they do not show exact information regarding height, only the illusion of height which means heights and slopes cannot be measured; and
  - (2) hachure lines tend to obscure other map detail.



Figure 5-1: hachures

- b. **Hill or Relief Shading** – This method shows, by darkness of colour, what hachures show by lines. Shading may be applied so that colours darken as the ground rises, or it may be applied as if the light was coming from one direction, so that one side of a hill is shown in a lighter shade than the other to give greater definition. Hill shading is often used on modern topographic maps in conjunction with contour lines as illustrated in Figure 5-2.

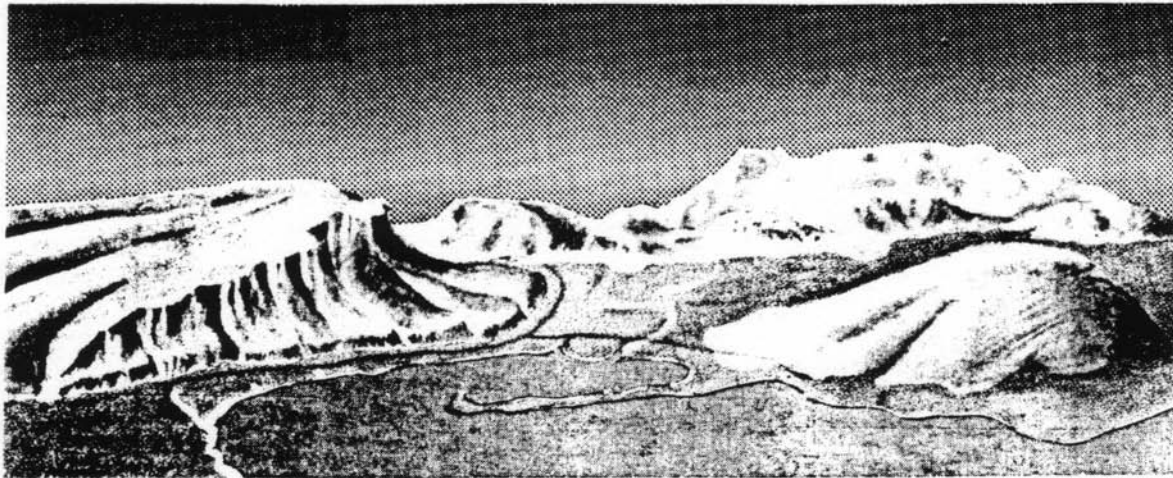

Figure 5-2: Oblique View of Area  
(see Figure 5-3 for the relief shading and contours of the same area)

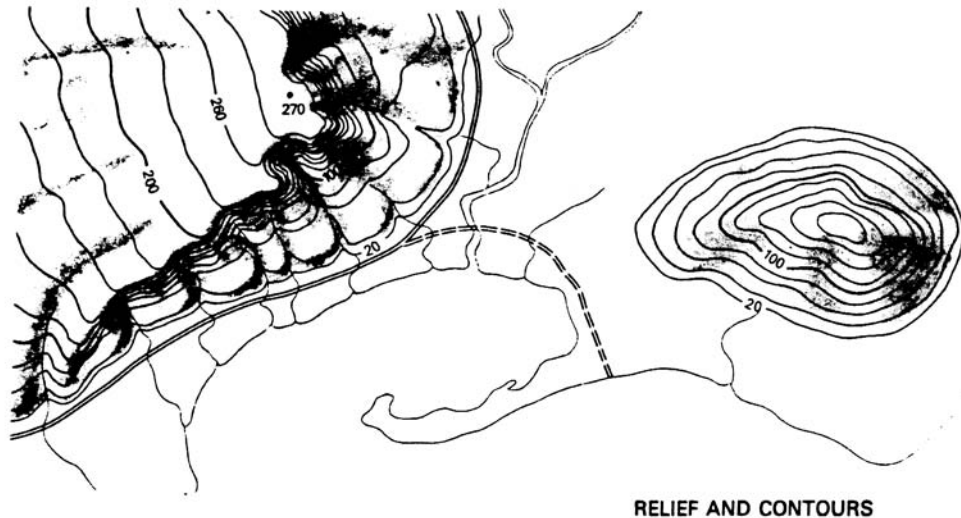

Figure 5-3: Contours and Relief Shading

- c. **Contours** – The most common way of showing the shape of the ground on modern maps is by the use of contour lines. Contour lines give no visual illusion of relief and failure to recognise this, may cause difficulty in understanding their purpose.
- (1) **SIMPLE PRINCIPLE** – The concept of a contour is very simple. It is an imaginary line drawn on a map, joining all places of equal height above a fixed datum line (usually sea level). These are shown in Figure 5-3.
  - (2) **CONTOUR HEIGHTS** – On the map, each contour is drawn at a specific height above a fixed datum and the vertical distance represented by each is the same. The difference in height between contours is called the Vertical Interval (VI) or the Contour Interval and is shown in the marginal information on the map. It is from the height and spacing of contours that the shape of the ground is deduced and accurately calculated if necessary. Some contours have the height shown at intervals along their length. On most maps these heights are printed so that they read facing uphill. This allows the reader to determine the direction of high ground. (See Figures 5-2 and 5-3.)

#### 5.4 CONTOUR PATTERNS

Each topographical feature, such as a spur or a knoll, is represented by its own particular contour pattern. Figure 5-4 shows some contour patterns. Important points to remember about contour patterns are:

- a. contour lines close together indicate steep slopes;
- b. contour lines far apart indicate gentle slopes;
- c. evenly spaced contour lines indicate uniform slopes;
- d. when the spacing of contour lines, reading from high to low, decreases, the slope is convex; and
- e. when the spacing of contour lines, reading from high to low, increases, the slope is concave.

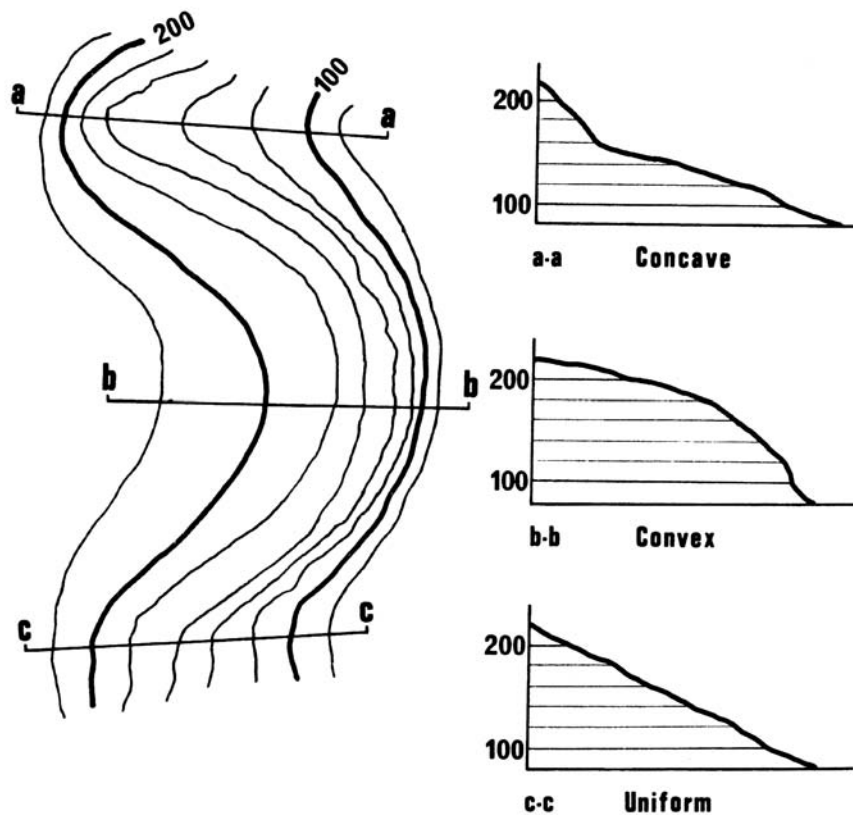

Figure 5-4: Contour Patterns

## REPRESENTATION OF HEIGHT

### 5.5 COMMON METHODS

Height without reference to shape is shown by fixing the height above sea level at selected points. Three common methods are described below in order of accuracy:

- a. **Bench Marks** – These are the most precise heights and are usually permanent marks cut into stones built into walls, or, on the side of triangulation pillars. The height given is the height of the mark above sea level.
- b. **Trigonometrical (Trig) Stations** – These are usually shown on maps and are normally defined on the ground by a mark in a concrete block under survey beacons.
- c. **Spot Elevations** – These are less accurate heights and are not definite marks on the ground. They are selected to indicate the height of the ground at ruling points such as tops of hills. Their accuracy will vary, but are at least as accurate as contours.

---

## MAP READING TERMINOLOGY

### 5.6 PHYSICAL FEATURES

Some common terms used in map reading to describe various physical features are listed below and illustrated in Figure 5-5.

- a. **Basin** – An area of reasonably level ground surrounded, or nearly surrounded, by hills; or an area drained by a river and its tributaries.
- b. **Crest** – The highest part of a hill or mountain range, or that line on a range of hills or mountains from which the ground slopes down in opposite directions.
- c. **Escarpment** – The steep hillside formed by a sudden drop in the general ground level, usually from a plateau.
- d. **Gorge** – A deep ravine, usually with steep/precipitous sides.
- e. **Knoll** – A small knob-like hill.
- f. **Plateau** – A tableland; an elevated region of considerable extent, generally fairly level.
- g. **Ravine** – A long, deep, steep valley worn by a stream.
- h. **Re-entrant** – A valley or ravine, usually between two spurs, running inwards towards the hill or mountain top.
- i. **Ridge** – The line along a hill or range of hills or mountains from which water flows in opposite directions; sometimes the crest of line of hills as it appears along the horizon.
- j. **Saddle** – A depression between adjacent hill or mountain tops; also called a col.
- k. **Spur** – A minor feature, generally in the form of a ridge, running out from a hill or mountain.
- l. **Undulating Ground** – Ground which rises and falls gently.

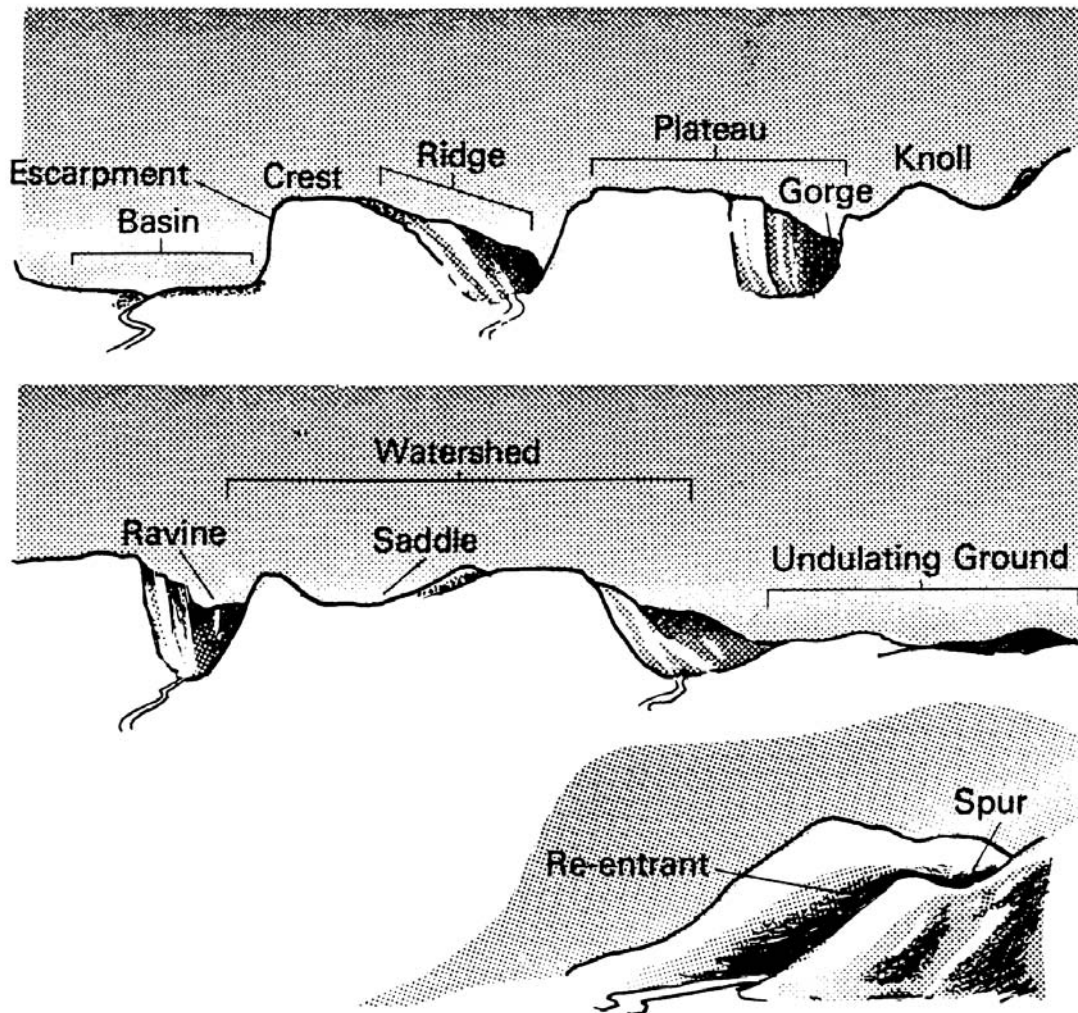
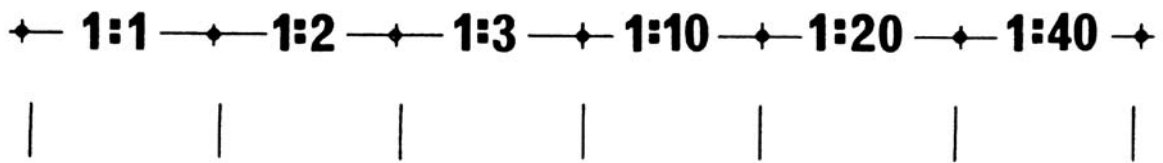

Figure 5-5: Physical Features

## GRADIENTS

- 5.7** The slope of the ground may be expressed as the angle the ground makes with the horizontal, but more commonly as a gradient, eg 1 in 10 or 1 in 20, which may be written as 1:10 or 1:20. A gradient of 1 in 10 means that in a distance of 10 units horizontally, the ground rises or falls 1 unit.
- 5.8** The eye exaggerates slopes to the extent that many people looking down a slope of 1:1 would say that it was almost vertical. Looking down a slope of 1:3 or 1:4 they would be convinced that it was at least 1:1. It is important, therefore, to be able to visualise the slope or gradient of the ground by studying the map. Figure 5-6 shows the effect of various gradients.





**a sand hill**

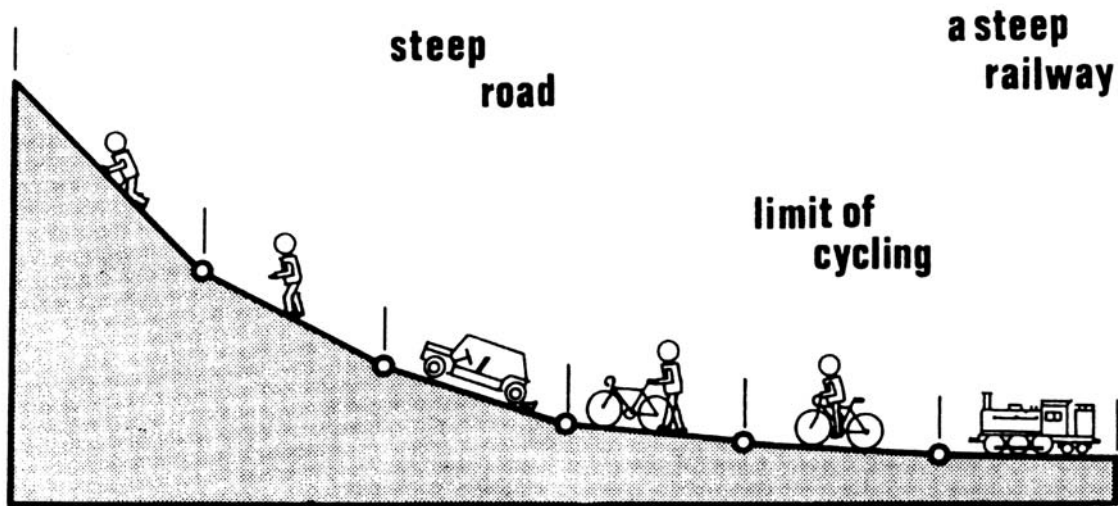

Figure 5-6: Gradients

**5.9**

**MEASURING GRADIENTS**

Gradients can be measured accurately using special instruments designed specifically for that purpose. Reasonable accurate results can be achieved by using information from the map. To calculate a gradient first measure the horizontal distance on the map between two successive contour lines and express this in the same unit as the contour interval. For example, if the contour interval is 20 metres and the distance measured on the map between two successive contours is 120 metres, the average gradient between these two contours is  $20/120 = 1/6$  or 1:6.

**5.10 CALCULATIONING DISTANCE BY PACING**

The following table (Table 5-1) gives an indication of the average number of paces it takes to cover a set distance. This may vary dependent on size of the person, their physical fitness, the current weather conditions, etc and it is to be used as guide only.

Gradient	Distance		Paces				Average Number per 200 m
	Map	Ground	Uphill		Downhill		
			Number per 100 m	Length in cm	Number per 100 m	Length in cm	
1 1/2:1	100	180	600	30	400	45	1000
1:1	100	141	313	45	235	60	548
1:2	100	112	187	60	165	68	352
1:3	100	105	154	68	140	75	294
1:5	100	100	133	75	133	75	166

**Table 5-1: Number of paces**

**Notes:**

Paces do NOT lengthen appreciably on steep downgrades.  
 Obstructions and traversing increases the number of paces.  
 A cautious approach shortens paces.  
 Experience and practice are the only sure means of achieving accuracy.

**5.11 MAXIMUM GRADIENT FOR VEHICULAR USE**

As a guide, the gradient of a road or track generally should not exceed 1:6 except for short distances and should never exceed 1:3.

**INTERVISIBILITY (LINE OF SIGHT)**

**5.12** Instances may arise where it will be necessary to determine what area of ground can be primarily covered by line of sight from a given point. Examples include:

- a. planning the establishment of radio communications (either VHF or UHF) from one point to another; and
- b. assessing the area of observation from a fire lookout tower.

**5.13 OBSTRUCTIONS**

In simple cases, an inspection of the map may clearly show whether or not there is intervening higher ground between the points under consideration. Obvious obstructions other than intervening higher ground may be trees or buildings and these must be taken into account.

**5.14** Where, however, the answer is not obvious by inspection, it is necessary to make a 'section' of the line of sight as explained below. A 'section:' is a diagram to show the rise and fall of the ground along a line between two points.

**5.15 MAKING A SECTION**

To make a full section between two points, on a contoured map as shown below do the following:

- a. First draw a line on the map between the two points A and B.
- b. Lay a straight edge of a piece of paper along the line AB and mark it at points A and B together with the points at which each contour cuts this line. Label each mark with its height, allowing an extra 10 metres for the heights of trees where necessary as in Figure 5-7.
- c. From each mark, drop lines on the paper perpendicular to the marked edge. Parallel to this marked edge, draw a series of parallel lines at a convenient scale to represent the height value of each of the contours cut by the line AB as in Figure 5-8.
- d. Make a mark on each vertical line where it cuts the height scale parallel corresponding to its height on the line AB. Join these marks with a smoothly curved line, allowing for the general slope of the ground between contours at the bottom of valleys and the tops of hills as in Figure 5-8. The slopes will be exaggerated, depending on the ratio of the map scale to the vertical height scale selected, but otherwise the section will give an accurate representation of the surface of the ground along the line AB.

The use of squared graph paper makes the drawing of a section easier and quicker.

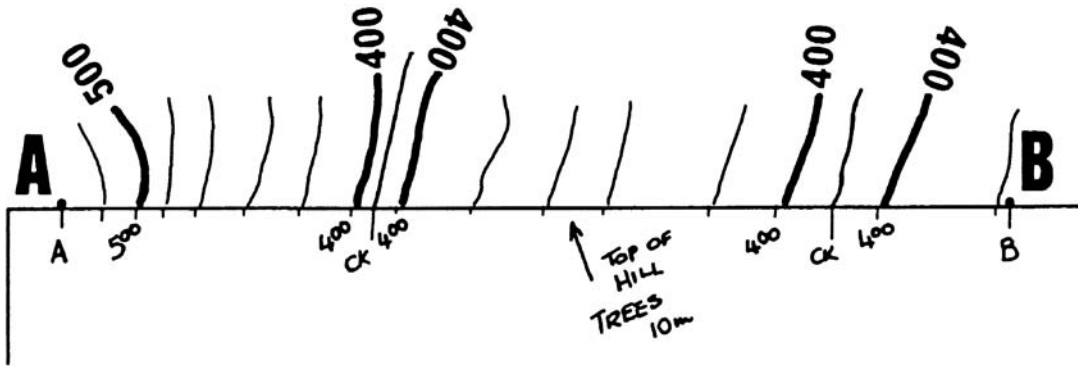

Figure 5-7: Making a Section

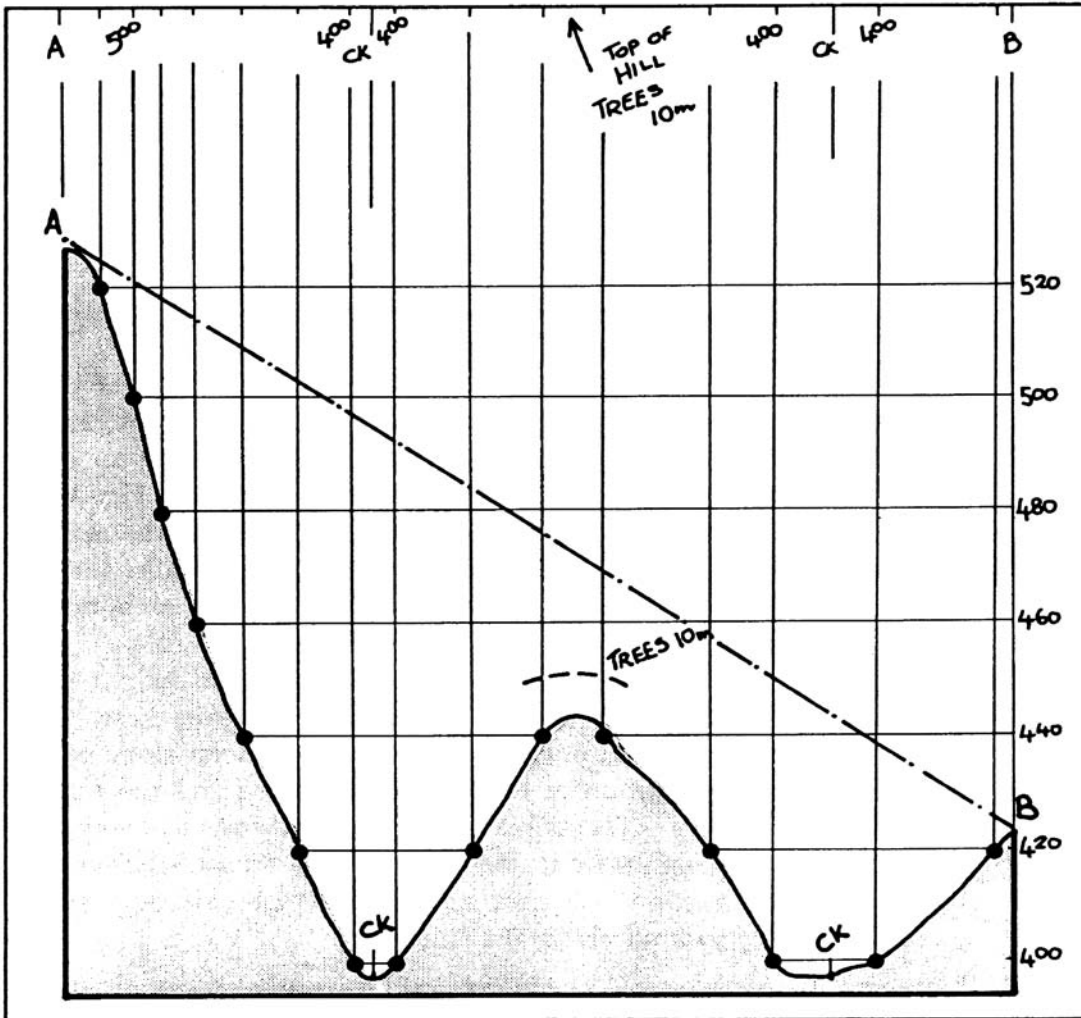

Figure 5-8: Making a Section to Determine Line of Sight

# CHAPTER 6

## Direction

### THE COMPASS

#### 6.1 CARDINAL POINTS

North, East, South and West are the four cardinal points of the compass. There are, in all, thirty-two points of the compass, but only sixteen are normally used in map reading.

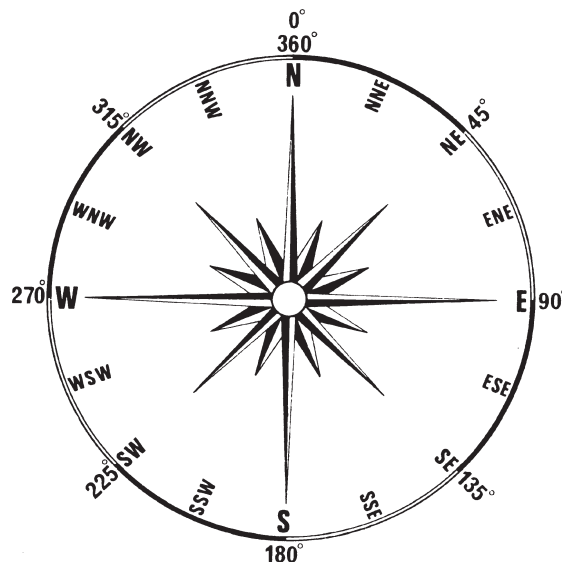

Figure 6-1: Points of the Compass

#### 6.2 THE DEGREE SYSTEM

The points of the compass give a rough indication of direction only. For greater accuracy, the circle is divided into 360 degrees; 0 (or 360) being the North point. The four quadrants of the circle are each 90 degrees and therefore the East, South, and West points are at 90, 180 and 270 degrees respectively.

#### 6.3

Each degree is sub-divided into 60 minutes and each minute into 60 seconds. Degrees are marked thus  $^{\circ}$ , minutes are marked thus  $'$ , and seconds are marked thus  $''$ . When the compass is being used, the sub-divisions of a degree are too small for practical use in land navigation and generally readings to one-half of a degree are sufficiently accurate for land navigation work.

**Note:** Some organisations, eg the Australian Army, have changed from the degree system to measuring angles in the European system of mils (6400 mils in a circle) but there is no intention to change to the mils system for non-military use in Australia for the measuring of angles.

**6.4 BEARINGS**

The purpose of a bearing is to give an accurate indication of the direction of one point from another. A bearing is the angle, measured clockwise, that a line makes with a fixed zero line. Unless stated otherwise, the zero line is always taken to be North.

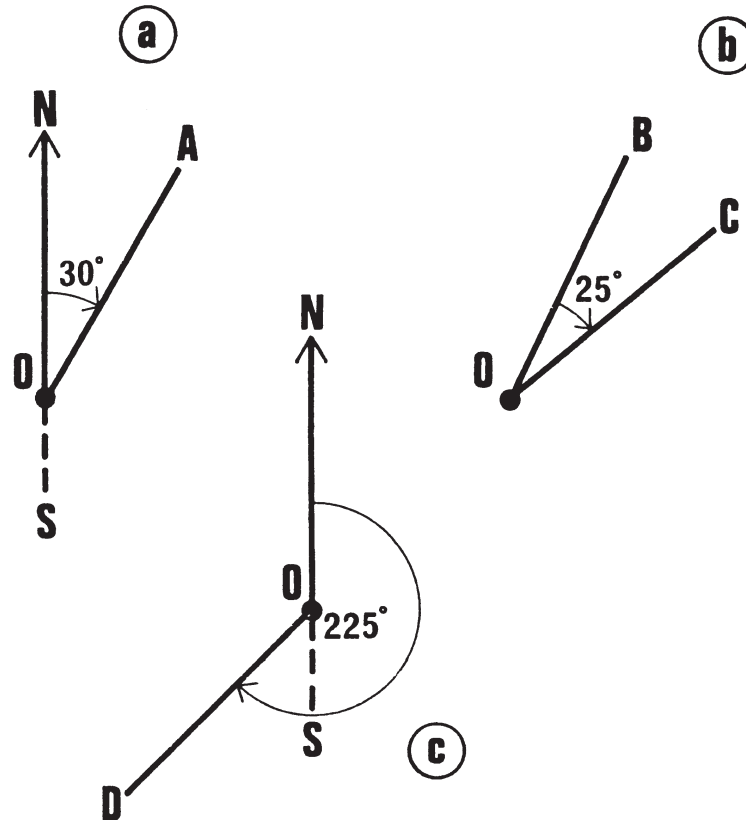

Figure 6-2: Bearings

**6.5** Standing at point O (Figure 6-2(a) and say that the bearing of A is 30', it means that the line OA makes an angle of 30° with the north-south line. If we say that the bearing of C (Figure 6-2 (b)) is 25° from the zero line OB, it means that the angle between OC and OB is 25°, measured clockwise.

**6.6** The diagram above (Figure 6-2 (c)) emphasises that the angle of a bearing is always measured clockwise from the zero line. The zero line is normally north-south and therefore bearings in any direction to the east on the north-south line fall between 0° and 180° and to the west fall between 180° and 360°.

**NORTH POINTS**

**6.7** In map reading, reference may be made to the three North Points. Each is explained in detail in paragraphs 6.08 to 6.10.

**6.8 TRUE NORTH**

The earth spins on an axis which passes through the North and South poles. The North pole is geographical North, or true North. Lines drawn from the North pole to the South pole are true north-south lines. True North is therefore the direction from any point on the earth's surface to the north pole.

**6.9 MAGNETIC NORTH**

To say that a compass points north is only relatively true because a compass needle does not point to the North Pole. It points to the North Magnetic Pole which differs from the North Pole. The position of the north magnetic pole varies slightly from year to year. The direction a compass needle points is known as Magnetic North.

**6.10 GRID NORTH**

The grid lines on a map do not lie true north and south except along one standard Easting called the central meridian. Elsewhere on the map they make an angle with the true north-south line. Since the grid lines are parallel, and since they are drawn on most maps, it is very convenient to use them for drawing or measuring bearings. The direction of the north-south grid lines (Eastings) is therefore known as Grid North.

**6.11 GRID AND TRUE BEARINGS**

All bearings plotted from a grided map are referred to as **grid bearings**, and not true bearings, since they are measured using Eastings as the fixed zero line. True bearings are not used as the difference between Grid North and True North is so small.

**PROTRACTORS**

**6.12** To accurately measure a bearing on a map, a protractor must be used. There are many different types of protractors available and although they differ in design and shape, they are used in much the same way.

**6.13** Most protractors are made of a solid plastic material, or wood with a thin plastic veneer, they may be circular, semi-circular or square. The outer edge of the protractor is graduated in degrees from 0 to 360, clockwise. Situated in a suitable position on the protractor is a north line and a centre point or hole.

**6.14 USING A PROTRACTOR**

Protractors are very simple to use as shown in Figure 6-3. To measure the bearing from the house at point O to the house at point A, proceed as follows:

- a. Using a straight edge and a fine pencil, join O and A as shown below. If the distance between the two points is small, or the line does not cut across an Easting, it is advisable to extend the line through the object to which the bearing is being taken to ensure that the line is visible when the protractor is positioned on the map and that it crosses an Easting.
- b. Place the protractor on the map and position it so that the centre point or hole is directly over the intersection of the line drawn in subparagraph a. and an Easting.
- c. The bearing can then be read off the graduated edge of the protractor where the pencil line meets it.

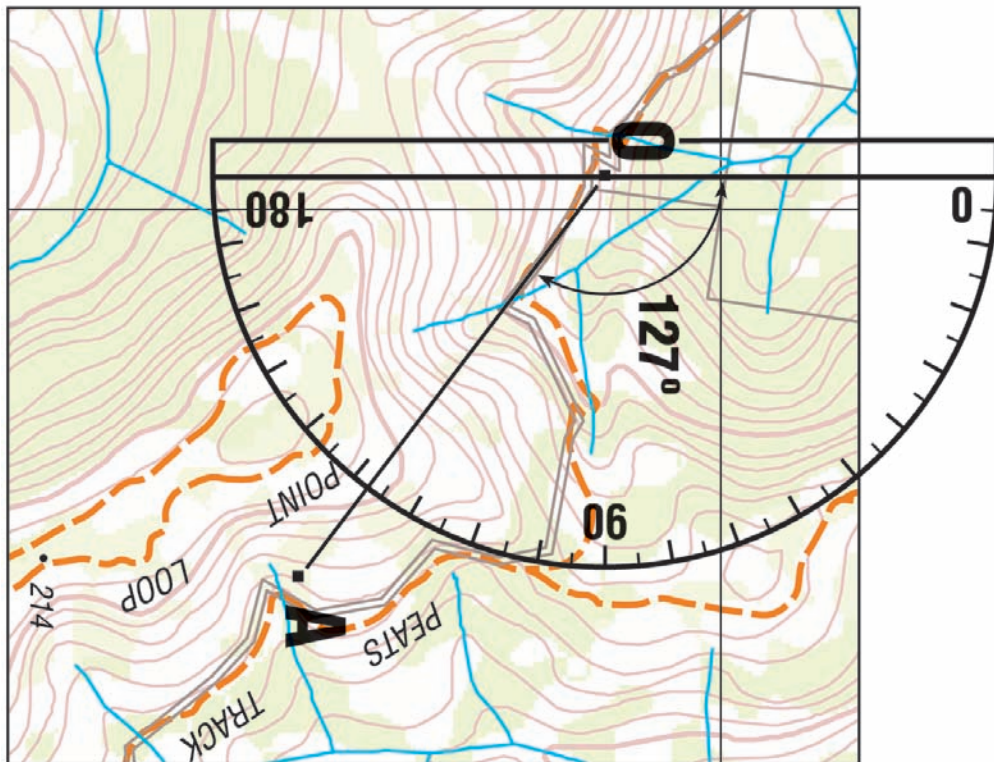
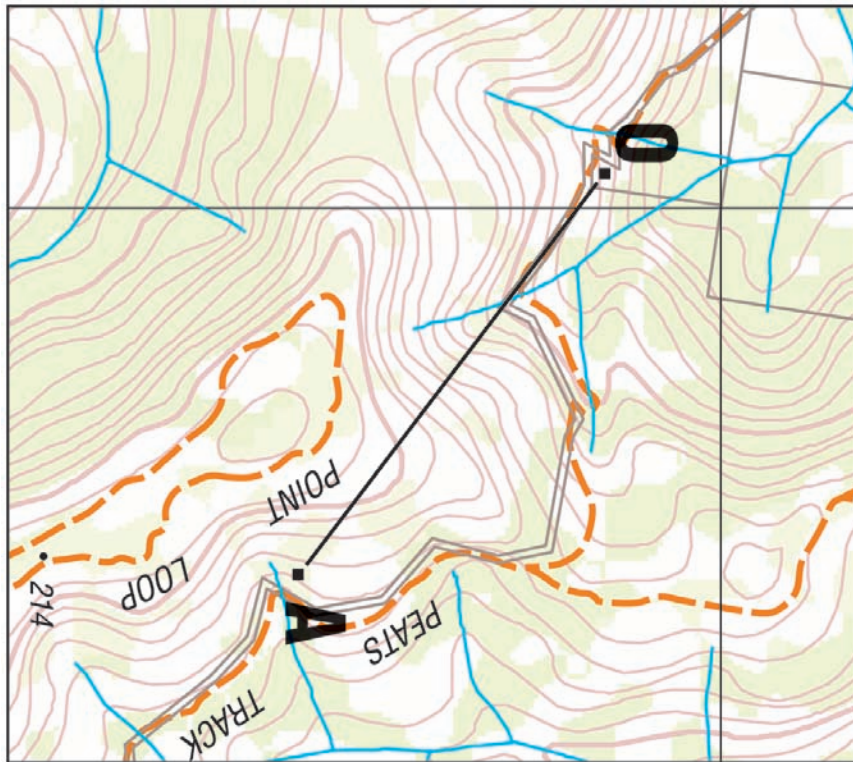

Figure 6-3: Using a Protractor



**6.15 PLOTTING A BEARING**

To plot a bearing on a map, do the following:

- a. Place the protractor on the map and position it so that the centre point or hole is directly over the point from which the bearing is to be plotted and the zero or north-south line is parallel to an Easting.
- b. Read off the bearing required on the graduated edge of the protractor and mark the map with a pencil.
- c. Remove the protractor and draw a thin line from the point of origin through the pencil mark. This line is the required grid bearing.

**6.16 THE DOUGLAS PROTRACTOR**

A protractor which is often used is the Douglas combined protractor and parallel rule. This protractor is square in shape and because of its dual function is desirable for general map work.

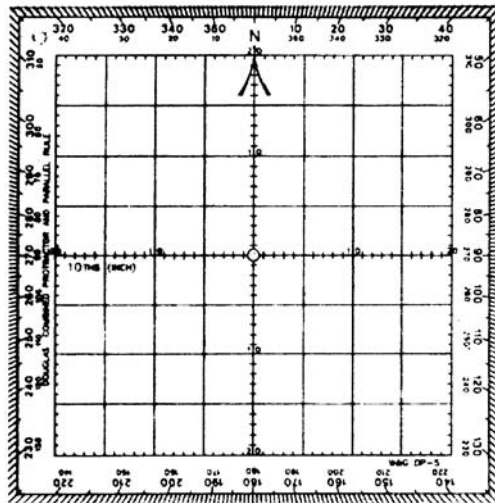

Figure 6-4: Douglas Protractor.

**MAGNETIC VARIATION/DECLINATION**

**6.17** The angle between the Magnetic North line and the Grid North line at any place is the magnetic variation (or magnetic declination) for that particular place.

**6.18 POLE MOVEMENT**

The position of the Magnetic pole is not fixed; it moves slightly from year to year. In consequence, the direction of Magnetic North and therefore the magnetic variation, also changes by a small amount each year. Though this change is not constant it can be forecast with sufficient accuracy over a number of years and details of the annual change are given in the marginal information. Note carefully whether the annual change has to be added or subtracted. If the annual change is the same direction as the magnetic variation it must be added; if they are opposite directions the annual change must be subtracted.

**6.19 ISOGONALS**

Lines joining places with equal magnetic variation are known as isogonals. They do not, as is sometimes supposed, themselves point in the direction of Magnetic North. It might be expected that isogonals would follow a regular pattern but the earth's magnetic field at any point is affected by the land and mountain masses and the presence of metallic ores. Therefore, the isogonals are pulled out of shape and follow no regular pattern.

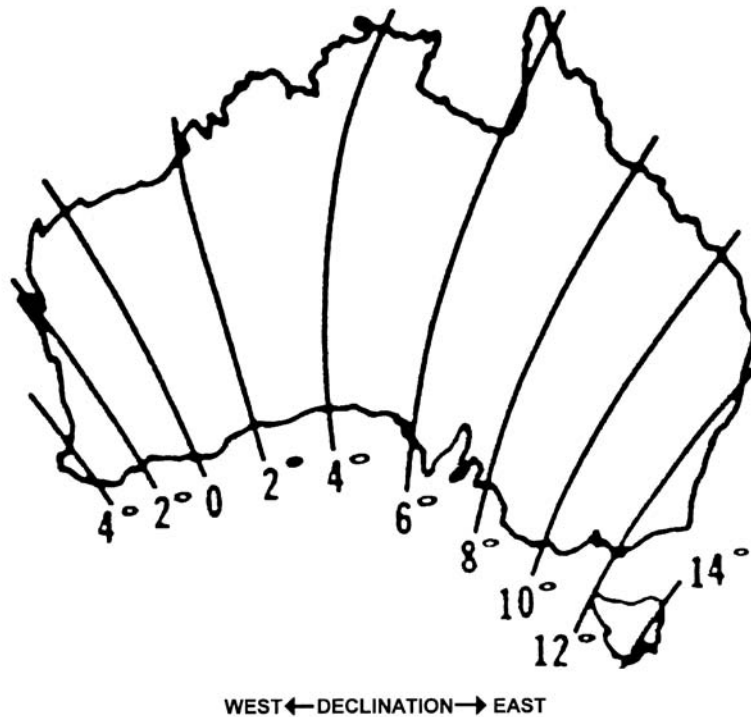

Figure 6-5: Isogonals

**CONVERSION OF BEARINGS**

**6.20** Compass bearings taken on the ground must be converted to grid bearings for plotting on a map. Conversely, grid bearings taken from a map will have to be converted to magnetic bearings before they can be used with a compass on the ground.

**6.21 CONVERSION PROBLEMS**

To convert a bearing from a grid to magnetic or magnetic to grid is a simple matter of adding or subtracting the magnetic variation. Unfortunately, it is easy to add when you should subtract, or subtract when you should add. To avoid this you should draw a diagram.

**6.22 EASTERLY VARIATION**

Figure 6-6 gives an example of how to convert a magnetic bearing, one taken by a compass, to a grid bearing taking into account a 14 degree easterly magnetic variation. The magnetic bearing of 50 degrees needs to have 14 degrees of easterly variation added to it to convert it to a grid bearing as the diagram indicates.

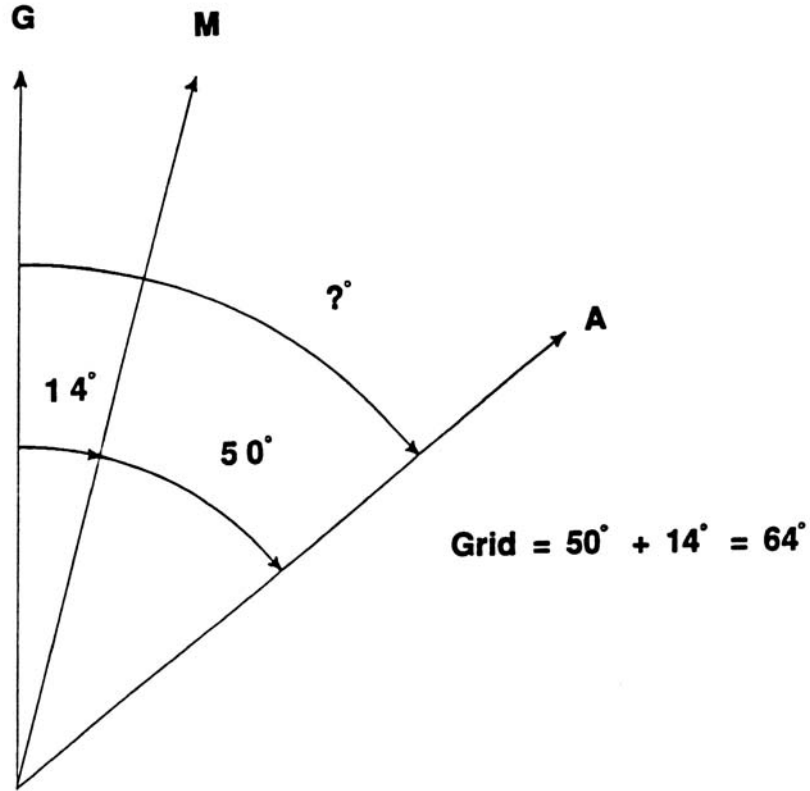

Figure 6-6: Conversion of Bearing (Magnetic to Grid, Variation East)

- 6.23** Figure 6-7 gives an example of how to convert a grid bearing, one taken from the map, to a magnetic bearing taking into account the same easterly magnetic variation. The grid bearing of 89 degrees needs to have 14 degrees of easterly variation subtracted from it as the diagram indicates.

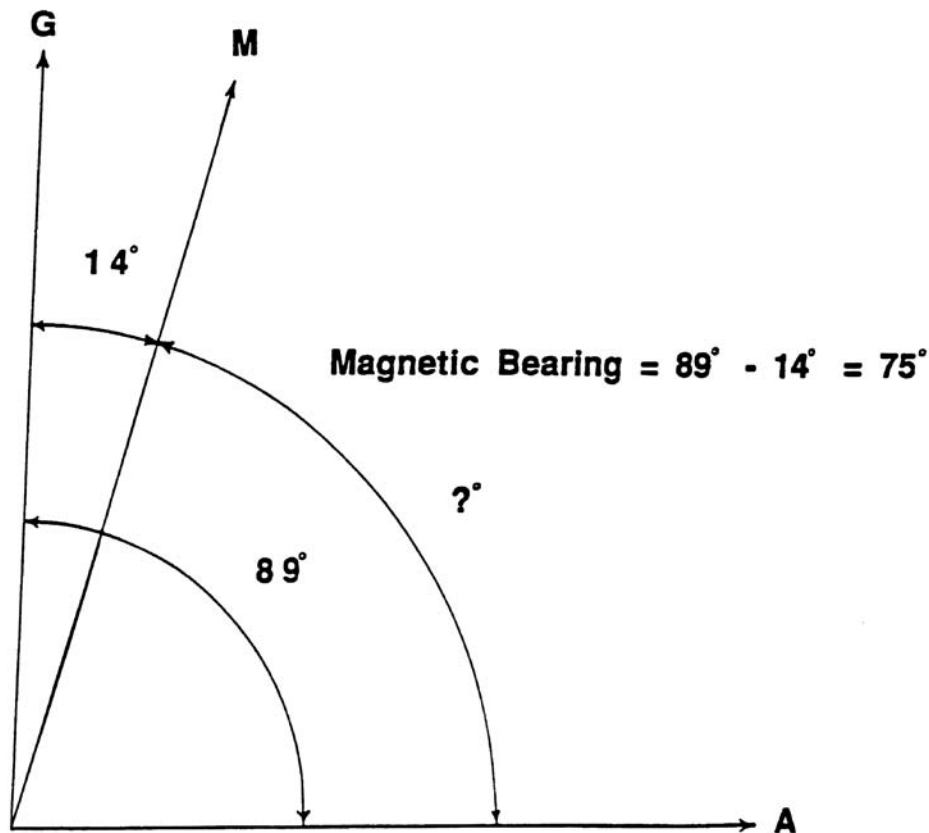

Figure 6-7: Conversion of Bearing (Grid to Magnetic, Variation East)

- 6.24 WESTERLY VARIATION**  
 The magnetic variation across the continent of Australia changes from East to West depending on location, therefore consideration must be given to conversions where the variation is Westerly rather than Easterly. The process in this case is the reverse of the Easterly examples as Figures 6-6 and 6-7 show.
- 6.25** A grid bearing of 50 degrees is to be converted to a magnetic bearing in a situation where the magnetic variation is 4 degrees West. In this case, as Figure 6-8 shows, the variation is added rather than subtracted. The resulting magnetic bearing is 54 degrees.

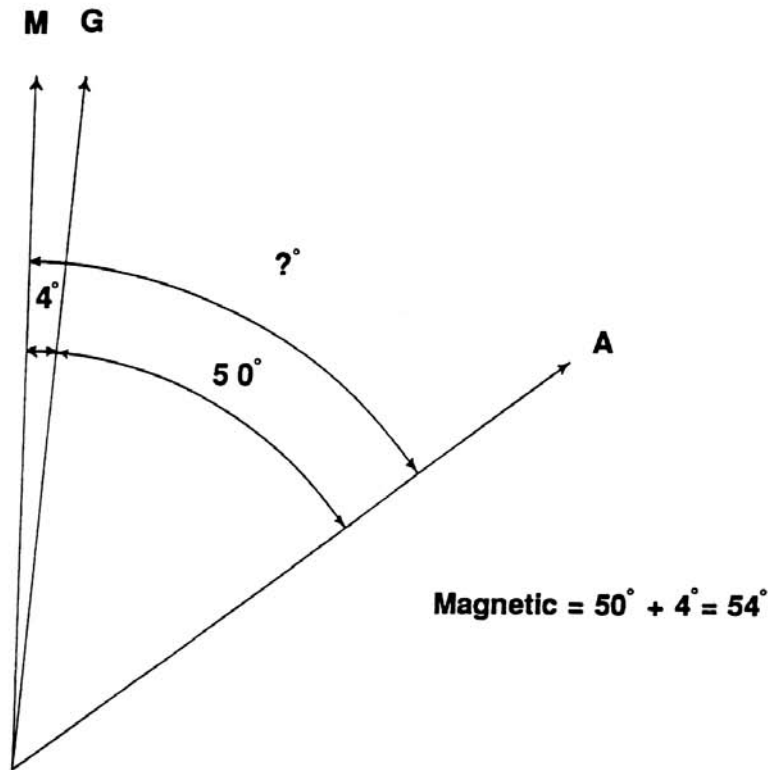

Figure 6-8: Conversion of Bearing (Grid to Magnetic, Variation West)

**6.26**

When it is necessary to convert a magnetic bearing to a grid bearing and the magnetic variation is West the variation is subtracted as is shown in Figure 6-9. The bearing of 60 degrees has the magnetic variation of 4 degrees subtracted from it to become 56 degrees magnetic as the diagram shows.

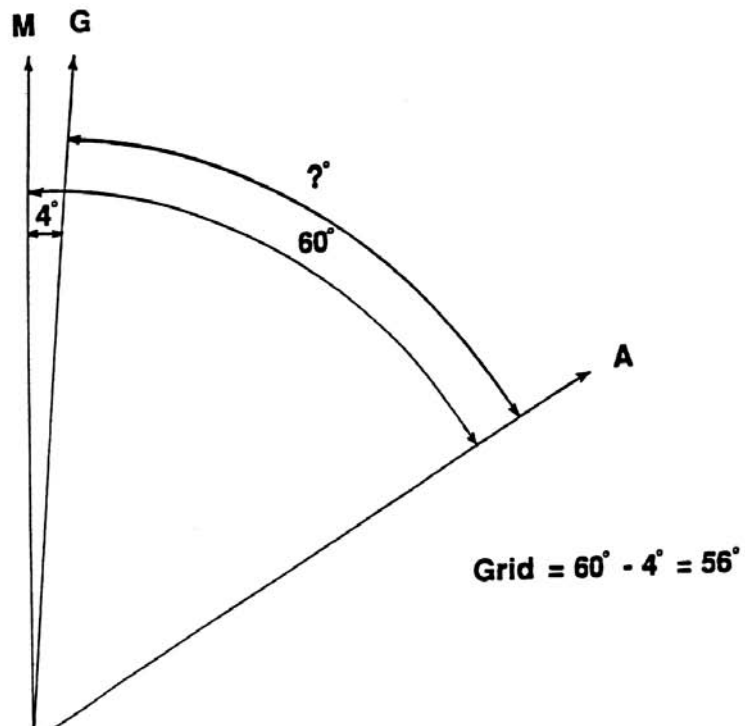

Figure 6-9: Conversion of Bearing (Magnetic to Grid, Variation West)

**6.27 CONVERSION DIAGRAM**

Remember to draw a diagram with the two north points (grid and magnetic) and the known bearing in its correct relation. It is then a relatively simple matter to calculate the unknown bearing by either adding or subtracting the magnetic variation.

**BACK BEARINGS**

**6.28** A bearing gives the direction of a line from the point of observation to an object. A back bearing gives the direction from the object back to the point of observation. It is clear from Figure 6-10 that the difference between the bearing and the back bearing is  $180^\circ$ . Therefore, given the bearing, to find the back bearing add  $180^\circ$ ; or if the bearing is more than  $180^\circ$  subtract  $180^\circ$ .

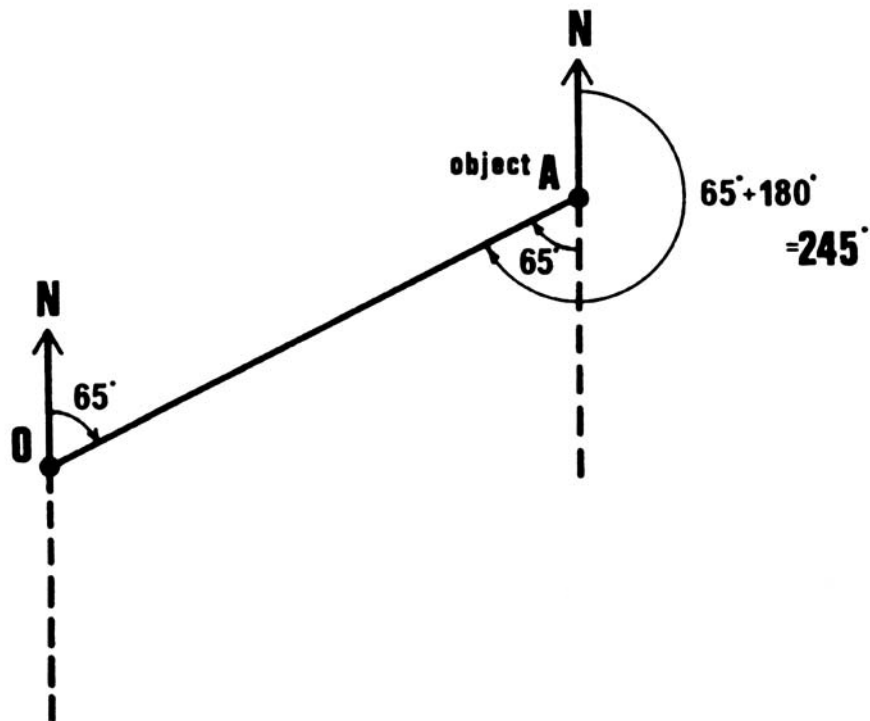

Figure 6-10: Back Bearings

# CHAPTER 7

---

## Compasses

### GENERAL

- 7.1 There are many types of compasses suitable for use in map reading and navigation. Magnetic compasses are most commonly used although electronic compasses are also suitable. Although magnetic compasses may differ in shape and size, the principle of operation is essentially the same. In brief, they consist of a magnetised needle accurately balanced in a pivot point set in the centre of a non-ferrous or plastic box. A card, graduated in degrees, is usually fixed to the top of the needle with the 360° mark directly over the north point of the needle. Situated on the box of the compass is a datum point (north) and sometimes an aiming point or protrusion along the same line.
- 7.2 In this chapter the types of compasses in common use and some general aspects in the use of the different compasses are dealt with separately.

### THE PRISMATIC COMPASS

- 7.3 There are a considerable number of compasses which can be described as prismatic. The operation of these compasses is essentially the same regardless of brand. The boxes of the compasses are filled with liquid to dampen the movement of the card so that it rotates gently and comes to rest quickly. Also provided is a magnifying prism which enables the reader to read the bearing on the card with much more accuracy. Figure 7-1 shows the main components of the prismatic compass and Figure 7-2 shows how to take a bearing using the prism.
- 7.4 **FIELD USE IN DAYLIGHT**
- Methods of using a prismatic compass by day are detailed below:
- a. **To take a bearing** – Hold the compass in a steady position in both hands with the thumb through the ring, the lid vertical, and the prism turned over in the reading position. Looking through the prism, line up the object with the hair line in the centre of the prism slot and read off the bearing on the card against the hair line.

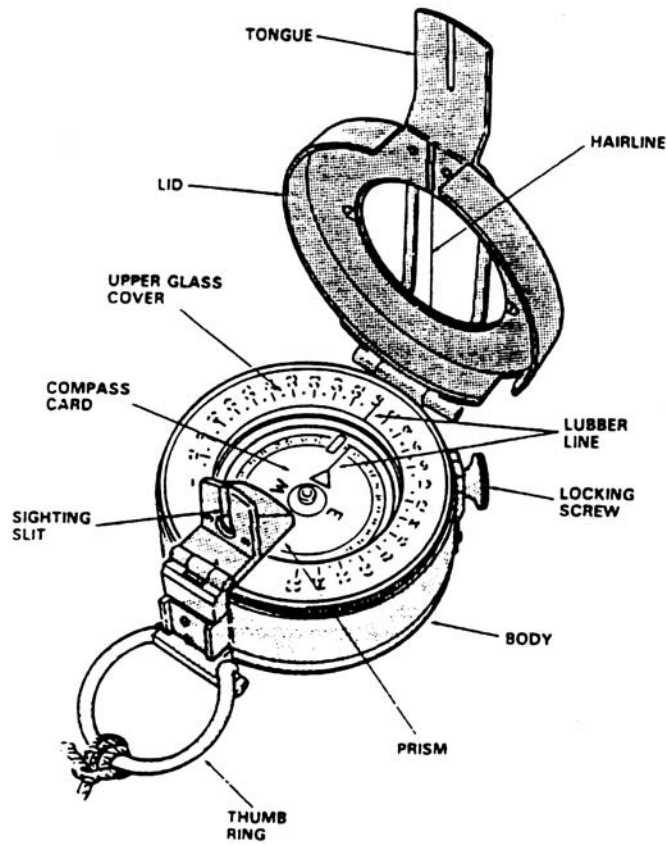

Figure 7-1: The Prismatic Compass

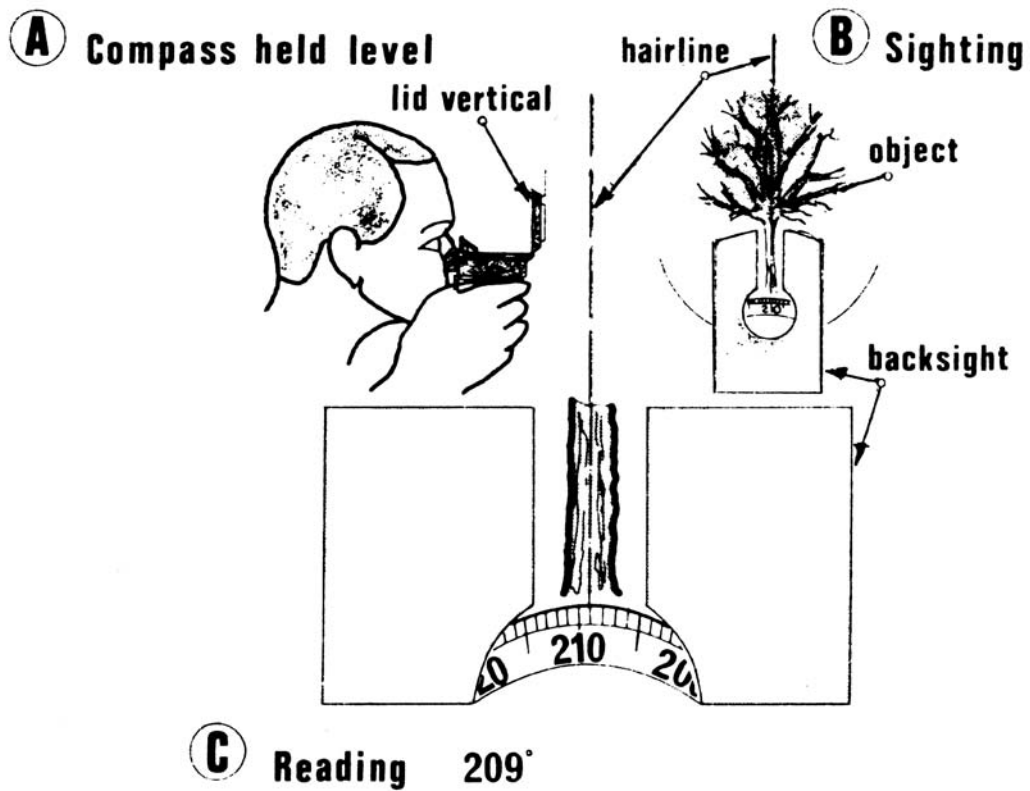

Figure 7-2: Taking a Bearing (Using the Prism)



- b. **To find the direction of a given bearing** – Looking through the prism turn the compass until the hair line cuts the given bearing and then note some object in the distance which is in line with the hair line. The object will be on the required bearing.
- c. **Using the compass without the prism** – Either of the above operations can be carried out without using the prism but with less accuracy. To take a bearing, open the compass out flat and line it up so that the tongue is directly in line with the object. The bearing is read from the inner circle on the compass against the lubber line. To find the direction of a bearing, turn the compass until the inner scale below the lubber line reads the given bearing. Rotate the body of the compass until the north point of the needle aligns with the north indicator on the glass cover. The tongue is then pointing in the required direction. To avoid errors, read with the eye vertically over the lubber line.

**7.5 SETTING A PRISMATIC COMPASS FOR NIGHT MOVEMENT**

With the compass opened and held flat, loosen the locking screw and turn the glass cover to set the required bearing against the lubber line. With the glass cover relocked, the compass is then turned until the luminous point of the north point and the luminous strip on the cover coincide. The tongue will then point in the required direction. For very rough setting, the markings on the outside cover may be used instead of the markings on the compass card.

**THE ORIENTEERING COMPASS**

7.6 Although initially designed for the sport of orienteering, these compasses are now made in many models and are used widely throughout the world by armed forces and many other organizations as general purpose compasses.

7.7 There are many different types of orienteering compasses available; however, the basic construction for all types remains the same. The compass enables the user to plot and calculate bearings rapidly and accurately on a map without the use of a protractor by combining, on a common base plate, both a compass and a protractor. Figure 7-3 below shows the major components a typical orienteering compass.

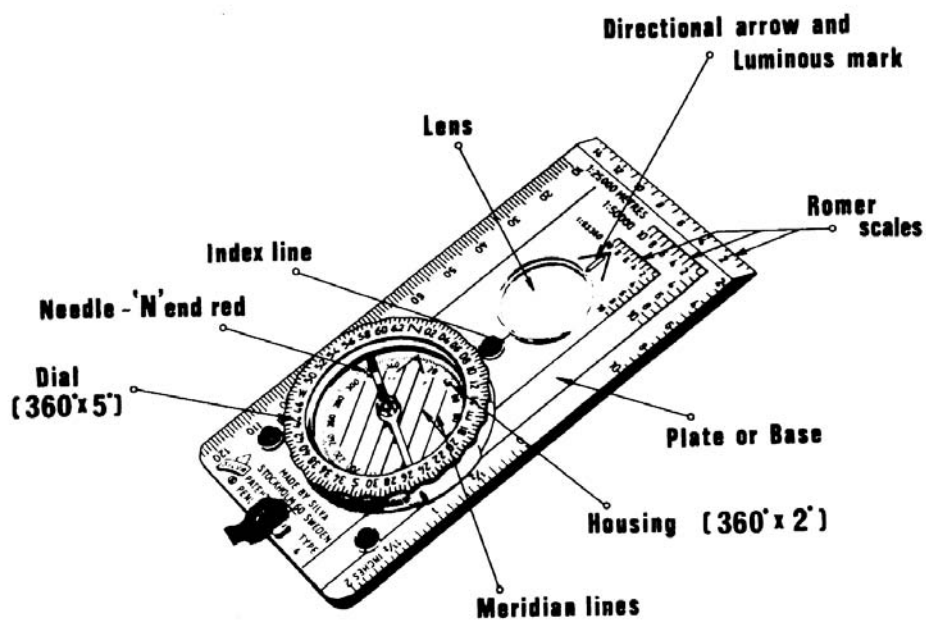

Figure 7-3: A typical orienteering Compass

### 7.8 USING AN ORIENTEERING COMPASS

The major applications and uses of the orienteering compass are detailed in the following paragraphs.

a. **Taking a Grid Bearing** – The procedure for calculating a grid bearing from a map, shown in Figure 7-4 is as follows:

- (1) **Step 1** – Place the long edge of the compass plate along the desired bearing (along line AB in Figure 7-4) making sure that the directional arrow on the compass plate points in the direction you wish to travel.
- (2) **Step 2** – Turn the compass housing so that the meridian lines are paralleled with the eastings on the map, and the north mark is pointed towards the top of the map.
- (3) **Step 3** – Read the grid bearing on the housing where the index line intersects it.

**Note:** The bearing that has been calculated is a Grid Bearing. This bearing must be converted to a magnetic bearing if it is intended to be set on the compass. The procedure for converting bearings is dealt with in Chapter 6.

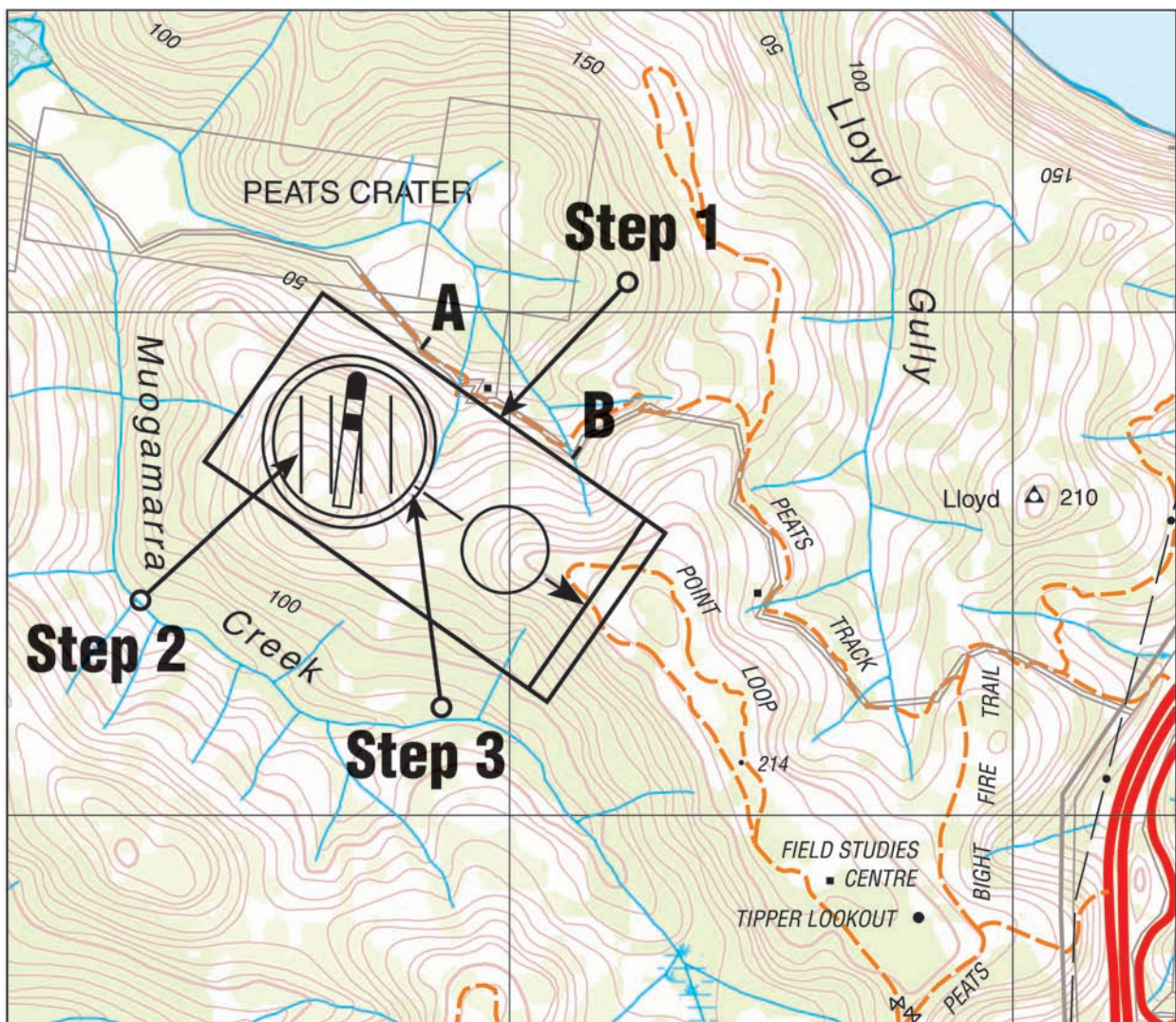

Figure 7-4: Taking a Grid Bearing Using an Orienteering Compass

- b. **Setting the Compass on a Magnetic Bearing** – To travel along a magnetic bearing use the compass as follows:
- (1) Set the magnetic bearing on the compass by rotating the compass housing until the required bearing is in line with the index line on the compass plate.
  - (2) Holding the compass flat in the palm of the hand, turn around until the red end of the compass needle points to the north mark on the compass housing and is parallel to the meridian lines.
  - (3) The direction arrow now points along the required magnetic bearing.
- c. **Taking a Magnetic Bearing** – The procedure for taking a magnetic bearing to an object is detailed below:
- (1) Hold the compass in the position shown in Figure 7-5 with the direction arrow pointing to the object.
  - (2) Rotate the compass housing until the red arrow of the meridian lines is directly beneath the red (north) end of the compass needle.
  - (3) Read the magnetic bearing on the housing where the index line intersects it.

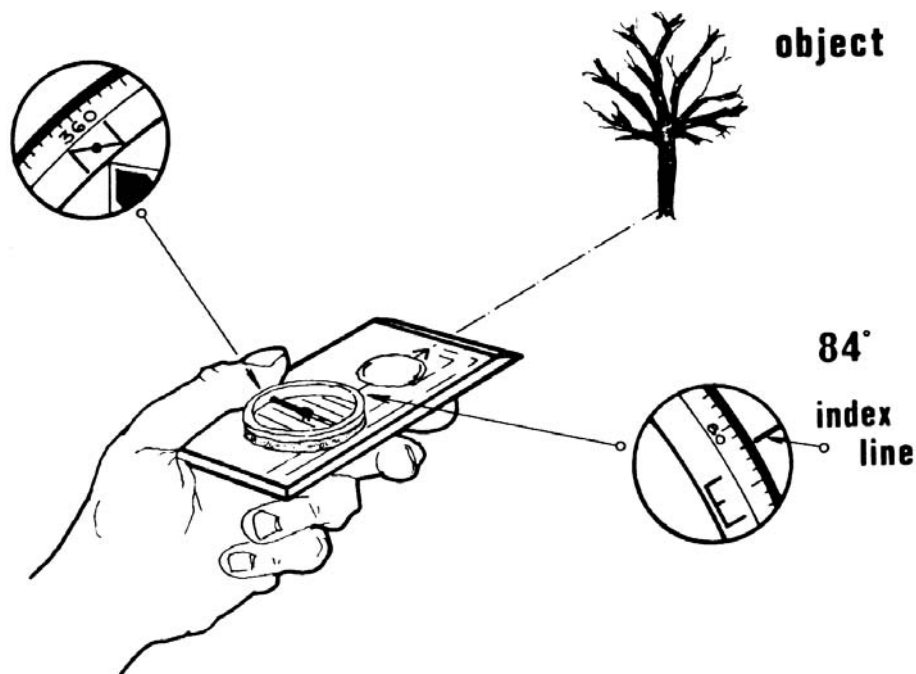

Figure 7-5: Taking a Magnetic Bearing Using an Orienteering Compass

## 7.9

### BACK BEARINGS

If the user is travelling on a given bearing and wishes to return to the original start point simply turn around to face roughly in the direction from which they have come and reverse the compass so that the direction arrow points towards the user. Orient the compass by turning the whole body until the red end of the compass needle points to the north point on the housing and travel in the direction in which the back of the compass plate faces.

## Compass reversed

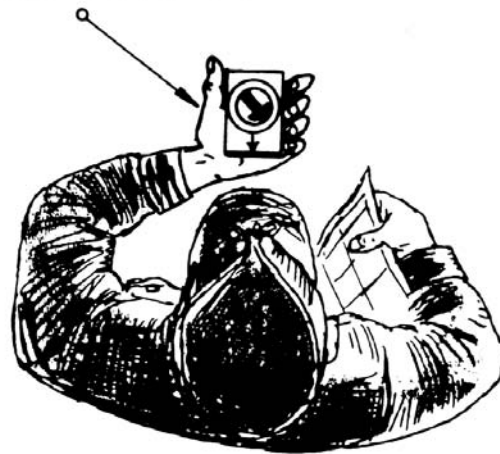

Figure 7-6: Back Bearings

### THE ELECTRONIC COMPASS

**7.10** The electronic compass is a battery operated hand held navigation tool. It is contained within a plastic casing and has an LED display.

**7.11** Some of the features of the electronic compass include:

- a. settings for magnetic and true bearings;
- b. storage for multiple declination angles;
- c. memory for storing route information;
- d. automatic back-bearing calculation;
- e. a clock and timer display; and
- f. a back light for night operations

**7.12** There is a variety of electronic compasses available and users should refer to manufacturers instructions for details on how these are used.

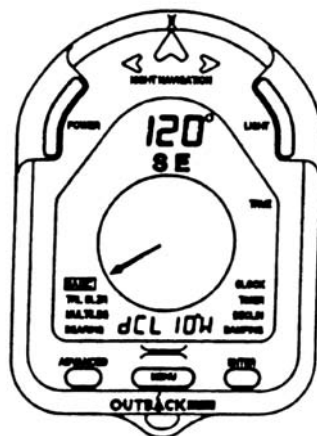

Figure 7-7: A Typical Electronic Compass

**7.13 ALTERING DIRECTION TO AVOID AN OBSTACLE**

There may be occasions when it will be necessary to alter the direction of travel in order to avoid a major obstacle. This is best done by travelling around the obstacle by a series of right angles. To carry out this manoeuvre with most compasses it necessitates altering the compass setting by 90° each time a change in direction is required. With the orienteering compass this can be done without any alterations to the original compass setting simply by taking advantage of the right angles of the compass plate as shown in Figure 7-8.

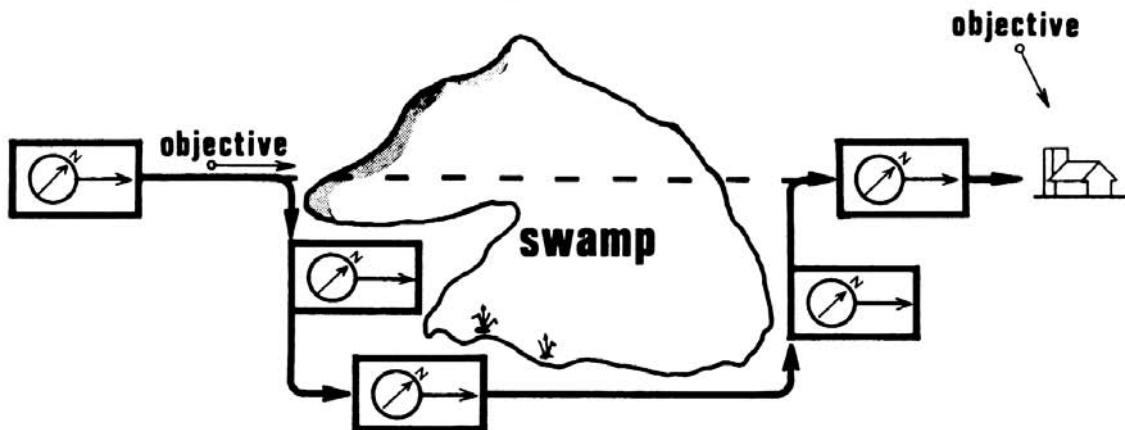

Figure 7-8: Avoiding an Obstacle

**7.14** Assume that a user wishes to avoid an obstacle by travelling around it to the right. For his first right hand turn he would simply alter the position of the compass in his hand and, maintaining the same setting, sight along the back edge of the compass plate from the left corner to the right corner. The user would then move along the new course for the required number of paces to avoid the obstacle. For the second turn (to the left) the user would hold the compass in the normal way and walk far enough to clear the obstacle. For the third turn (again to the left) the user would maintain the same setting but sight along the back edge of the compass plate from the right corner to the left corner. By travelling the same number of paces as for the first turn it should place the user back on line with the initial direction of travel. For the final turn (to the right) simply orient the compass with the direction arrow pointing directly ahead of. The obstacle has been by-passed and the user can now continue towards the intended destination.

**COMPASS ERRORS**

**7.15** When using a magnetic compass, the user should be aware of the two main causes of variations in compass readings.

**7.16 INDIVIDUAL COMPASS ERROR**  
 Each compass has its individual variation, that is, it does not point exactly to magnetic north. The compass needle itself may not be quite true with the markings on the card, and slight divergences may be caused in other ways. The error may be negligible or comparatively large and therefore it is important to have compasses checked regularly. Any minor error should be noted on the compass and when readings are taken, allowance must be made for the individual variation. A compass with a large individual variation should be either recalibrated or replaced.

**7.17 LOCAL MAGNETIC ATTRACTION**

Local magnetic attraction is due to the presence of iron or iron ore nearby. The compass is a delicate instrument and quite small quantities of iron have a surprisingly large effect on its behaviour. A wrist watch or steel framed spectacles will affect the compass reading. Take the precaution of seeing that all iron or steel objects are at a safe distance before using the compass. Small articles will be safe in a trouser pocket but larger articles should be placed two or three metres away.

- a. **Safe Distances** – Listed below are the safe distances from various common objects.

Transmission high tension lines	80m
Large vehicles	76m
Car/utility	60m
Fencing wire/concrete	10m
Pick, axe or shovel	3m

- b. **Determining Magnetic Attraction** – To check for local magnetic attraction, select two points about 100m apart. From one, take a bearing to the other. Then move to the other and take a bearing back to the first. The two bearings should differ by 180 degrees, the back bearing. If they do not, there is magnetic disturbance at one point or the other, or at both.

**Note:** Never use a compass on a map that is resting on the bonnet or boot of a motor vehicle.

# CHAPTER 8

---

## Map Orientation, Position Fixing and Map Enlargement

### MAP SETTING

**8.1** A map is said to be oriented or 'set' when the features on the map are in the same relative position as the features on the ground. There are two methods of setting a map.

**8.2** **SETTING BY INSPECTION**

This is the simplest and quickest method of setting a map. The procedure is to select objects on the ground that can be identified on the map. Turn the map so that the objects on the map are lined up with those on the ground. The map is now set or oriented.

**8.3** **SETTING BY COMPASS**

This is by far the more accurate method of setting the map and should be used when it is difficult to identify sufficient detail on the map and on the ground. Place the compass on the map over the magnetic variation diagram with the compass axis along the magnetic north line of the diagram. Rotate map and compass until the north point of the compass needle points directly along the axis line of the compass.

### POSITION FIXING BY COMPASS RESECTION

**8.4** **PROCEDURE**

The following procedure (see Figure 8-1) can be used to fix your position when you can recognise features on the ground and on the map but are unable to fix your exact position on the map:

- a. Select two or three prominent, widely spaced features that you can recognise on the map and on the ground.
- b. Using the compass, take a magnetic bearing to the first feature.
- c. Convert the grid bearing to a back bearing and plot this back bearing with a thin line from the feature on the map.
- d. Convert the grid bearing to a back bearing and plot this back bearing with a thin line from the feature on the map.
- e. Carry out the above procedure until you have plotted the back bearings on the map from each of the features you have selected.
- f. Your position is that point where the back bearings intersect. If they form a small triangle, then your position is the centre of the triangle. However, there should be sufficient detail on the ground and the map to confirm this.

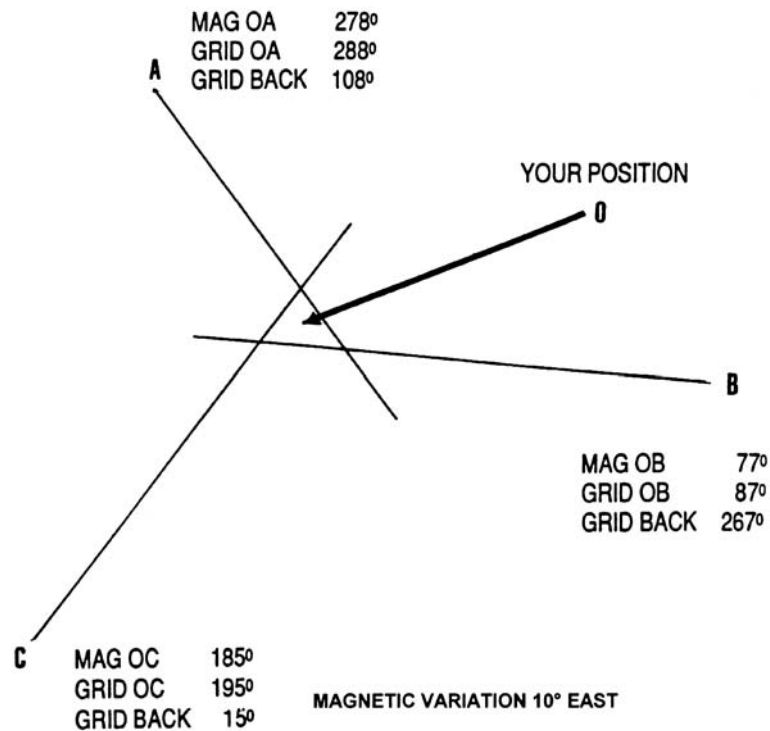

Figure 8-1: Resection – Triangle of Error

## RESECTION BY OVERLAY

**8.5** Occasionally, when trying to conduct a resection in the field, it is awkward due to the lack of suitable resources. A small piece of clear plastic that is firm enough to draw on can be used, this should be a part of any navigation kit.

The following method is used to conduct a resection:

- a. Take magnetic bearings to three features.
- b. Mark a north-south line with a zero point on the plastic with a permanent felt pen. A fine point permanent overhead marker is ideal, and should also be carried as a part of a navigation kit.
- c. Working from the zero point of the north-south line, plot the magnetic bearings taken to the features. Magnetic bearings should not be converted to grid bearings at all using this method.
- d. Now place the marked plastic onto the map and bring the plotted lines into alignment with the three corresponding features. Once aligned, your position is indicated by the zero point on the north-south line. When the plotted lines are aligned with their corresponding features, the north-south line will automatically be offset from grid north by an equal angle to the magnetic grid-magnetic angle.



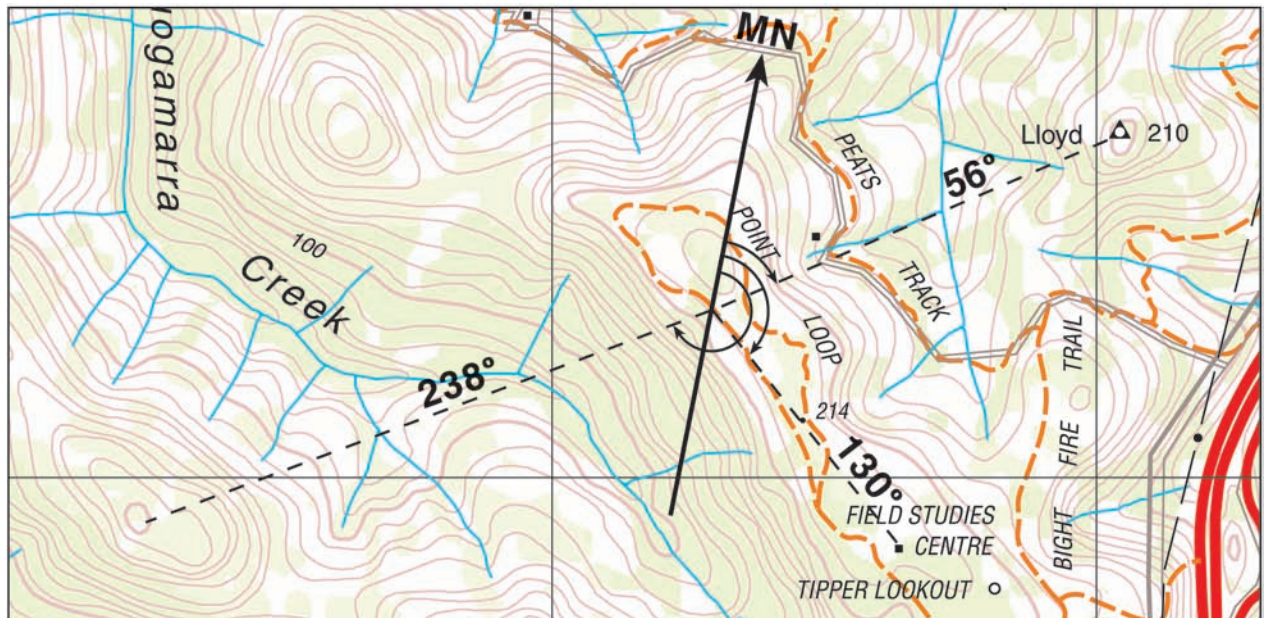

Figure 8-2: Resection by Overlay

## MAP ENLARGEMENT

- 8.6** It is often desirable to produce a copy of a map, or portion of a map, with a larger scale than that of the original. This enlargement provides a basis for a more detailed sketch and more space for notes and descriptions.
- 8.7** **METHOD OF ENLARGEMENT**  
 A simple method of enlarging a map is to use the 'square' method. First draw a square on the map outlining the particular area to be enlarged. If only one grid square is to be enlarged, then use the existing printed grid lines as the border. On a separate sheet of paper draw a square in the same proportion as the desired increase in scale, eg if the desired scale is double that of the original, then the square on the sheet of paper must be double the size of the square on the map. Divide the areas of both the original and the enlarged square in to similar small geometrical patterns, eg an equal number of smaller squares or a 'union jack' type design. The detail from the original square is then transcribed, by eye, to the enlargement being plotted in the same relative position as it occupies in the original map square. Figure 8-3 shows an example of a map enlargement using this method.
- 8.8** **ADDING INFORMATION**  
 A simple and effective way of adding information to an enlarged map is by using a compass and protractor. Firstly, select a datum point, preferably a feature or object which has been transcribed from the original map. From this datum point take magnetic bearings to new objects which are to be included on the enlargement. Convert the magnetic bearings to grid bearings, judge the distance and plot them on the enlargement. Using this method, a relatively accurate and up-to-date map may be produced.

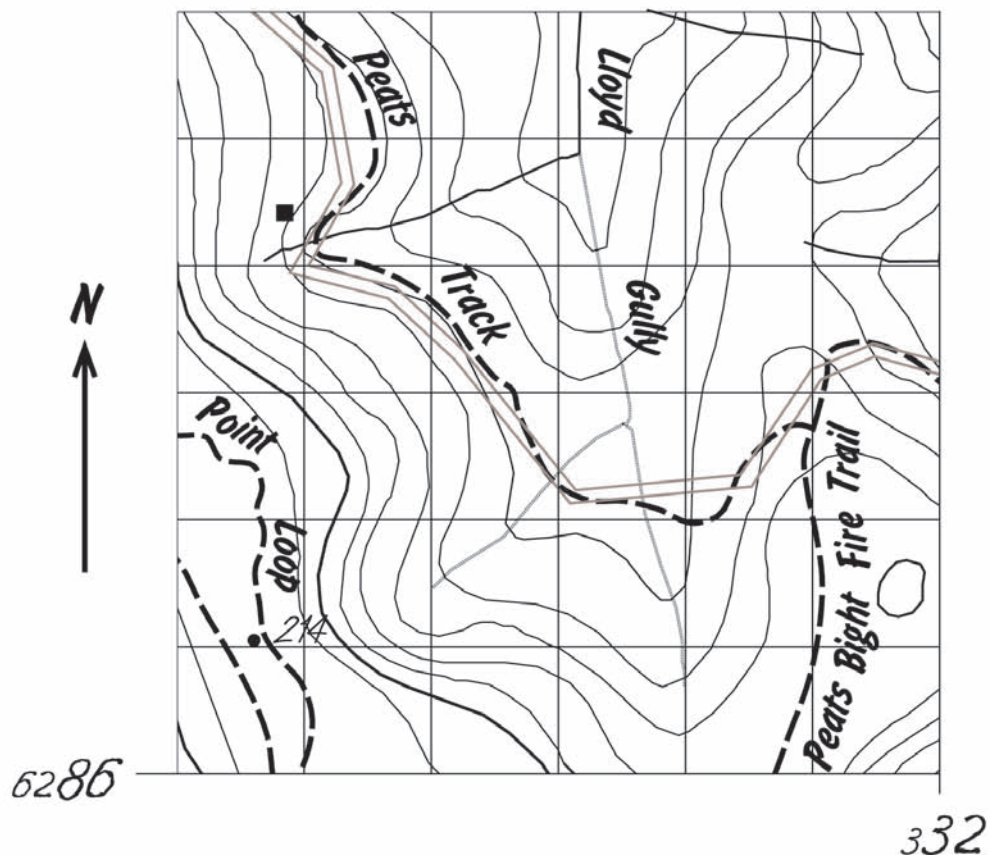

Figure 8-3: Map Enlargement

# CHAPTER 9

---

## Cross-Country Navigation

### INTRODUCTION

#### 9.1 GENERAL

Rugged terrain and dense vegetation can impose additional difficulties on cross-country navigation. In thickly timbered areas visibility is often reduced to a few metres and recognisable landmarks are few and far between. Bad weather, with low cloud, fog, rain or snow may occur, requiring reliance on map and compass for cross-country navigation.

9.2 The purpose of this Chapter is to detail important points which will assist with cross-country navigation.

### NAVIGATION AIDS

#### 9.3 MAPS

Maps are the most important navigation aid and as such should be carefully studied as a preliminary to cross country navigation. This study will provide the answer to many questions, such as the best route to be taken and areas to be avoided. It also enables the user to visualise the lie of the land, to assist with sense of direction and to increase confidence.

#### 9.4 AERIAL PHOTOGRAPHY

This provides a valuable check to map reading. For further information see Chapter 10.

#### 9.5 COMPASS

The compass is a valuable aid to cross-country navigation, particularly when moving at night or through dense vegetation where it is difficult to identify recognisable landmarks.

#### 9.6 IMPROVISED NAVIGATION BY THE SUN

There are several methods that can assist with navigation when a compass is not available and these are detailed below:

a. **Watch Method**

- (1) If the watch is set on daylight saving time, convert it to standard time. When south of the Tropic of Capricorn, hold the watch so that the 12 of the clock points to the sun. This can be checked by ensuring that the shadow of a vertical stick falls along the 12 axis. The direction of NORTH is then found by bisecting the angle between 12 of the clock and the hour-hand (Figure 9-1).
- (2) When north of the Tropic of Cancer hold the watch so that the hour-hand (when set on standard time) points to the sun. The direction of SOUTH is then found by bisecting the angle between 12 of the clock and the hour-hand (Figure 9-1).

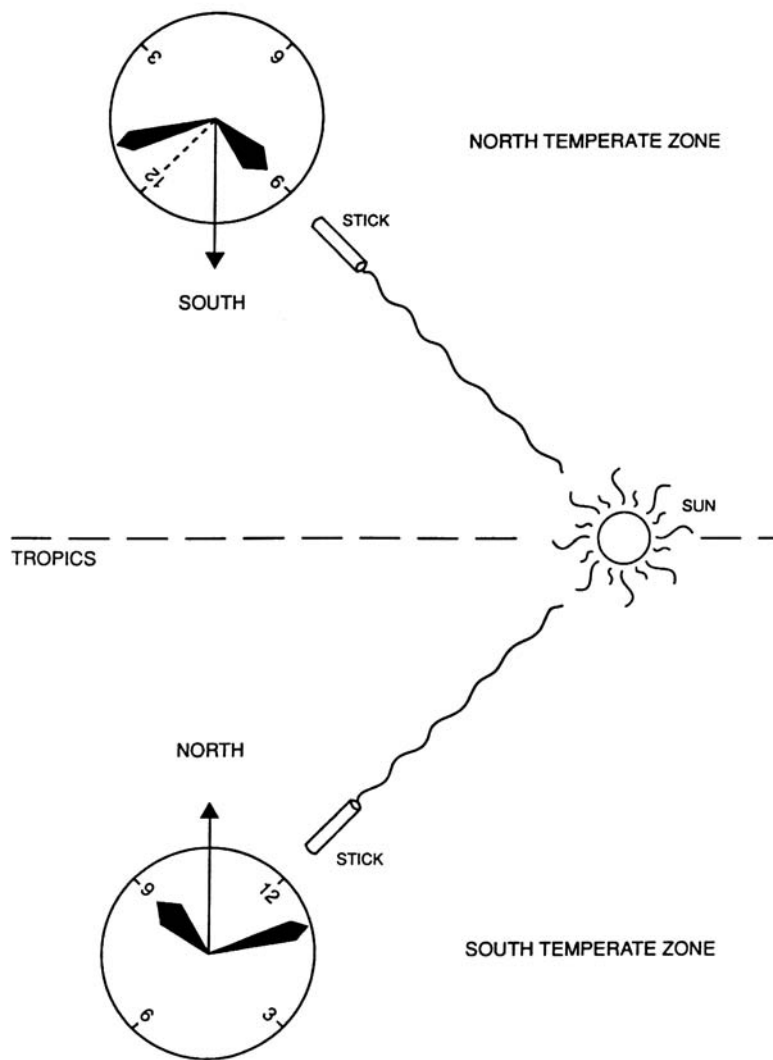

Figure 9-1: Direction from the Sun – Watch Method

- (3) The watch method can be used between the Tropics of Cancer and Capricorn, provided the sun's seasonal movements are known. If the sun is vertically overhead at midday, the method will not be very accurate and then the sun should only be used in its early and late phases for the general direction of east or west.
  - (4) In the case of a digital watch, the method described is not directly applicable. It is necessary to draw a standard watch face on the ground or a piece of paper for this method to be used, otherwise it is the same.
- b. **Shadow Stick Method** – The shadow stick method is very accurate and, for something like 5000 years, it was the basis of all surveying. Its major drawback is that a person must remain in the one location for several hours over midday.
- (1) Before noon, a level space is cleared which is exposed to sunlight. On this space, a straight stick is erected and set vertically with an improvised plumb bob.
  - (2) A circle is then described about the stick with the radius equal to its shadow, by using a sharp twig on the end of a string as compasses.

- (3) As the shadow moves, its end is marked at intervals. These marks will form an ellipse, except during the equinoxes when they form a straight line. The ellipse formed from the shadow's end will cut the circle at a second point after midday. A line drawn between the start and second point is a true east-west line (Figure 9-2).
- (4) Greatest accuracy can be obtained using the shadow stick from about 10am until 2pm.

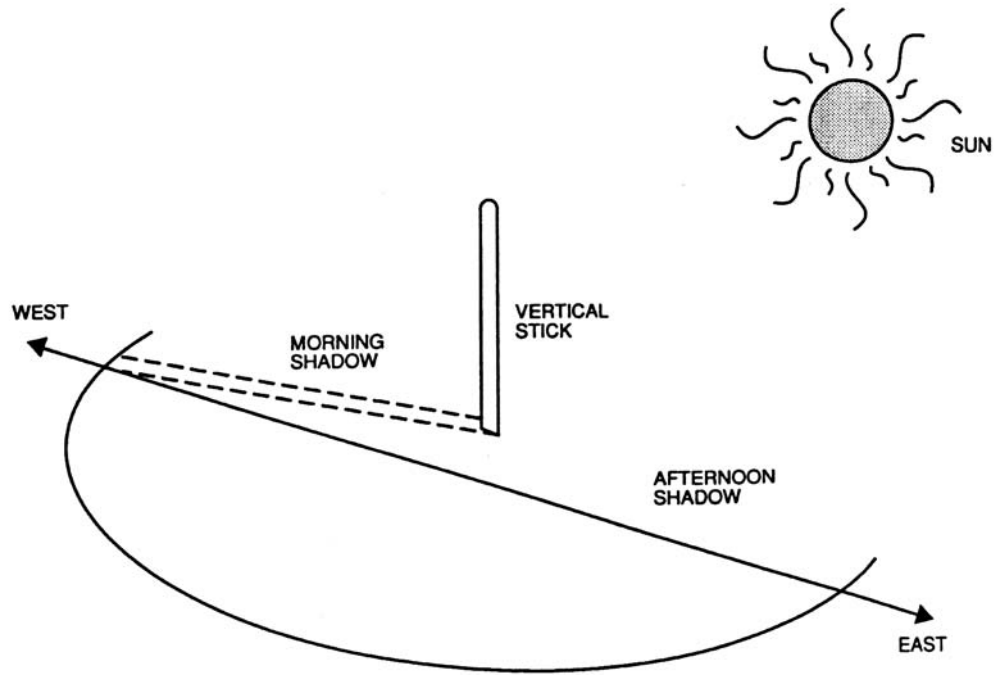

Figure 9-2: Direction from the Sun – Shadow Stick Method

**9.7 DIRECTION FROM THE STARS**

The two main constellations that can be seen in the southern skies that can provide direction are:

- a. **Southern Cross** – To find south you need to first find the Southern Cross in the night sky. Once you find the constellation you need to imagine extending the length of the longest axis of the Southern Cross four and a half times towards the south. Once you do this, imagine dropping a vertical line from that point down onto the horizon. South will be in that direction.

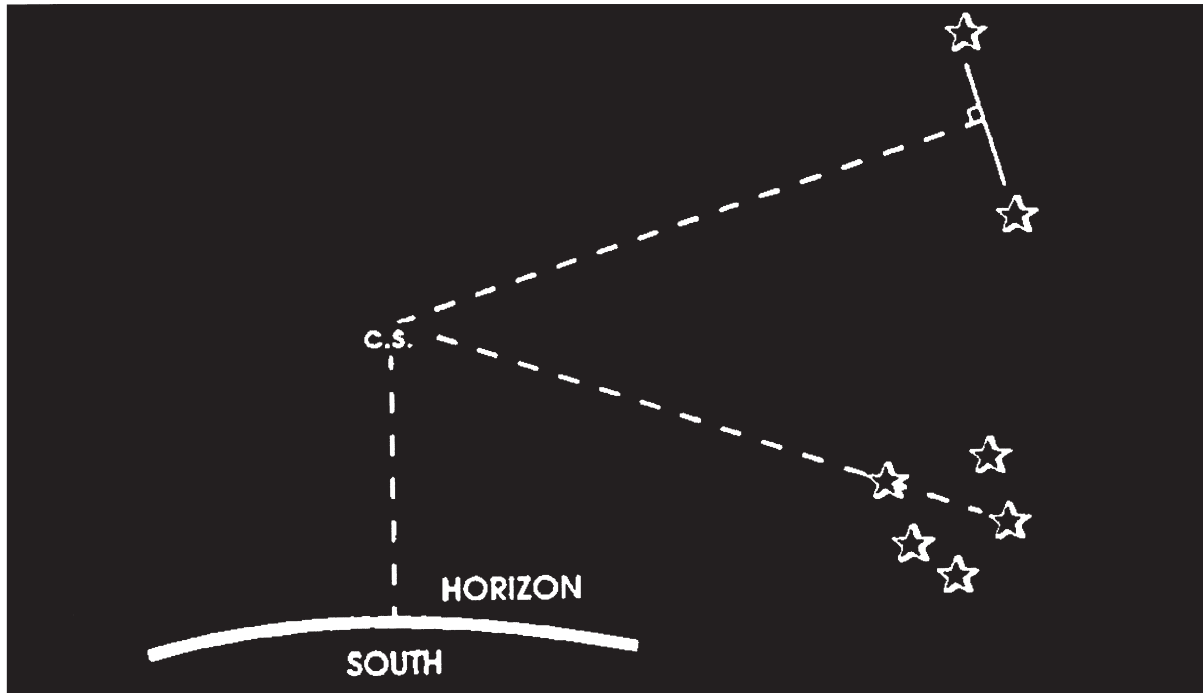

Figure 9-3: Southern Cross

- b. **The Orion Constellation** – When in the tropics, the Southern Cross may be difficult to see and the Orion Constellation may be used instead. This constellation rises due east and sets due west. By running an imaginary line through its two north stars, you can determine the direction east-west.

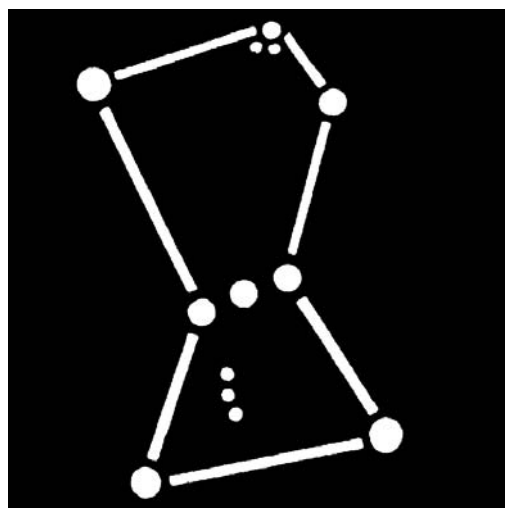

Figure 9-4: Orion Constellation

**9.8 PLANNING**

It is essential that, before setting off on a course, detailed planning is carried out. Particular aspects which should be undertaken are detailed in the following paragraphs.

**9.9 MAP STUDY**

This was mentioned in paragraph 9.3 as the essential preliminary to planning. In deciding the best route from one point to another, the following factors should be considered:

- a. **The 'Grain' of the Country** – It is far easier to follow the grain of the country than to go against it and therefore a direct route in the form of a straight line is practical only in relatively flat open country. It is useless in mountainous terrain.
- b. **Ridges** – Vegetation along ridges is generally less dense than in valleys. Also there are often animal tracks which add to ease of travel on ridges compared to valleys.
- c. **Rivers** – While rivers are useful aids to direction keeping, it is generally poor policy to follow them. In rugged country they are windy and are usually bordered by dense vegetation.

**9.10 NAVIGATION DATA SHEET**

Before starting a course, the chosen route should be divided into legs. Each should terminate at an easily recognisable object. Then produce a Navigation Data Sheet for the entire route which gives significant information for each leg of the route. It forms a valuable ready reference for the user.

Serial	From	To	Magnetic Bearing	Distance In Metres	Estimated Time In Minutes	Going	Remarks
(a)	(b)	(c)	(d)	(e)	(f)	(g)	(h)
1	561703	567709 Hut	32°	920	25	a. 400m gentle downhill, light timber b. 300m gentle uphill, open c. 200m uphill medium timber	Creek - 400m flows left to right  Dirt road at 750m
2	567709	563724 Ruin	285°	1600	50	a. Undulating ground, sloping right to left, medium timber	Creeks at 400m and 1300m
3	563724	554721 Knoll	212°	950	40	a. 300m flat, light timber b. 300m gentle uphill, medium timber c. 350m steep	
4	554721	561703	132°	1900	60	a. 400m down spur, medium timber b. 900m undulating with high ground on right, light timber c. 600m open across valley	Creek at 1600m flows right to left

Figure 9-5: Navigation Data Sheet

## MAINTAINING DIRECTION USING A COMPASS

**9.11** When moving through dense vegetation it is important that continuous check be made using the compass.

### **9.12 PREFERRED METHOD**

The best method of maintaining a given magnetic bearing is to select a prominent object (such as a tree), which lies on the bearing, and move to it. Then select another object on the bearing and move to that. Continue with this method until the destination is reached. If it is impossible to find a prominent object on the bearing then send another person forward about 100 metres, correct them onto the bearing and then proceed to them. Again repeat this procedure until the destination is reached.

### **9.13 CHECKING**

Once a course commences, checking must be continuous. Areas requiring particular attention are covered below.

#### **a. Location**

- (1) All features, hills and rivers should be checked as they are reached and identified on the map. Note the direction of flow of all streams and rivers and check with the map.
- (2) Tracks need to be identified but should always be regarded with suspicion. It is easy to place too much confidence in a track which may not be the one marked on the map.

**b. Distance Travelled** – It is very important, particularly when moving through vegetation, to know the distance which has been covered. There are two basic methods of achieving this:

- (1) **PACING** – This is generally accepted as being the more reliable method. Distances can be counted in number of paces, which, for the individual, can be translated into kilometres depending on the type of country and the average length of the pace. Experience has shown that over long distances it is better to count right foot paces only rather than each pace. To make recording easier, use small pebbles or seeds and transfer these from one pocket to another at each hundred paces or, if it is available, one of the modern pace counters are a useful aid. For a 76cm (30 inches) pace, 657 right foot paces will equal one kilometre. When estimating distance from the map, allowances must be made for the rise and fall of the ground. Where the measured distance on the map is 1000 metres, it will only be accurate if the ground is flat. If there is a hill included in the 1000 metres, its heights will have to be taken into account and the pacing count adjusted for climbing it on one side and going down the other.
- (2) **TIME** – Distance can also be calculated from the time in relation to speed of walking in kilometres per hour. For the average person walking over fairly flat country, a 76cm (30 inches) pace will result in a speed of about 5 kilometres per hour.

**c. Predicting Walking Time** – A rule for predicting walking time in Australian conditions is as follows: For an average walker, carrying a medium pack, allow one hour for:

- (1) every 5km of easy going;
- (2) every 3 km of easy scrambling;
- (3) every 1.5km of extremely rough country, deep sand, soft snow or thick bush; and



- (4) add one hour for every 500 metres up and one hour for every 1000 metres down.

For every five hours, allow up to one hour for the effects of fatigue.

**9.14 SUMMARY**

Cross-country navigation is not easy, but the difficulties are easily overstated. Providing methodical map study and planning are undertaken, followed by careful use of the map and compass, many of the problems should be overcome. With experience, individuals will gain confidence in themselves, their maps and their compasses. Once this confidence has developed, a feel for the country and a sense of direction will become instinctive.

**9.15 NAVIGATION UNDER SPECIAL CONDITIONS**

The following table describes some techniques that may be useful when navigating in certain conditions:

TYPE	CHARACTERISTICS	TECHNIQUES
Thick vegetation	Close country navigation is characterised by limited visibility and slow rate of movement.	Navigating in these conditions requires continual reference to the compass, and pacing, preferably by group average method. Measured bearings must be strictly followed and tendency to veer randomly towards easier going is to be avoided.
Desert Conditions	Magnetic interference from the vehicle and navigator is travelling in may cause errors in navigation	The navigator must continually dismount from the vehicle to take bearings. This may make movement unacceptably slow and consideration may be given to use GPS for navigation.
From a Vehicle – roads and cross Country	Roads can be misleading, especially if they are new or have changed since the map was produced. There may be a risk of bogging and tyre punctures when navigating off road.	Careful planning of the intended route, and knowledge of the area the navigator is travelling in should help avoid errors.

**Table 9-1: Navigation under Special Conditions**

## **ACTION IF LOST**

### **9.16 CONSIDERATIONS**

If lost, navigators should not act hastily. They should halt and consider:

- a. whether they have drifted left or right of their intended line;
- b. whether they could have already passed the objective, and whether the time and distance travelled was badly estimated;
- c. whether the ground covered conformed with the mental picture formed during the map study of the going expected from the map;
- d. whether there are any features in the area which will help to fix the position, or enable a resection to be conducted; and
- e. the possibility of the local magnetic attraction, compass error, or inaccuracy of the map to be a factor in 'becoming lost', but extreme care should be taken before attributing one's 'being lost' to the inaccuracy of the map.

### **9.17 POSITION FIXING**

As a result of careful consideration, it should be possible to narrow the position down to two or three probable location. A short reconnaissance in opposite directions should bring back sufficient information to allow a fix of the position.

### **9.18 BRIEFING DETAILS**

Leaders must always brief their teams on the action to be taken if they become separated from the group. The brief must be kept simple and the action required should remain the same for all legs of the route. If they are told to move in specific directions, it should be worded in terms of 'north' or 'south' rather than 'left' or 'right', as direction can then be found with only a basic knowledge of the movement of the sun and stars. For example, 'move east to the railway, then follow south'. This information should be included in the orders given at the start of the operation.

# CHAPTER 10

---

## Aerial Photography

### INTRODUCTION

**10.1** Aerial photographs (or 'air photos') are documents which contain detailed and accurate information of what exists on the ground. They are the basis of all modern maps and are a permanent record which can be reproduced, studied and restudied for various purposes by different users. Air photos do not replace topographical maps, nor do they eliminate the need for ground reconnaissance, however, used in conjunction with other navigational aids they provide a good source of information. Recent air photos are often much more up to date than available maps but the currency of both needs to be checked. Air photo reading is a highly specialised skill and this manual provides only an introduction to the subject.

### PHOTO READING AND PHOTO INTERPRETATION

**10.2** A distinction is made between the terms 'photo reading' and 'photo interpretation' as follows:

#### **10.3 PHOTO READING**

Photo reading involves the simple recognition of natural or cultural features from photographs without analysis of their meaning. Photo reading requires the ability to recognise familiar objects from their appearance on the air photo, to orientate the photo, to determine scale and to determine distance and direction.

#### **10.4 PHOTO INTERPRETATION**

Photographic interpretation involves the utilisation of special systems, techniques, and processes of analysing photographs, which enables skilled personnel to extract information from photographs and to determine the significance and implications of images in the area in which they are found.

### PHOTO-MAP COMPARISON

**10.5** Both maps and air photos have their own peculiarities, their advantages and disadvantages. Neither will furnish by themselves all the information available. It is therefore necessary to study both together.

#### **10.6 MAPS**

Maps show features represented by symbols, explained in a legend, and as such there is generally little room to accurately show every feature. Small or narrow features are usually exaggerated in size and small shapes are generalised, eg roads. Maps are usually out of date, but do show the North Point, place names and coordinates and are therefore more easily read than air photos.

**10.7 AIR PHOTOS**

Air photos show everything that is visible and is up to date at the time of exposure. Lack of detail (coordinates etc.) sometimes makes air photos difficult to orientate and read and usually much more time is required to make a detailed study of an air photo than the same area as depicted on the map.

**10.8 SUMMARY**

Briefly, the map gives a clear, broadly true, but usually out of date picture of the ground. A current air photograph gives an extremely detailed and up to date picture, but one which needs careful reading and which can contain some serious distortions such as poor focus and loss of scale at the extremities of the photo. This is clearly illustrated in Figure 10-1.

**TYPES OF AERIAL PHOTOGRAPHY**

**10.9** An aerial photograph is any photo taken from the air. There are several categories but the two most commonly used are:

- a. vertical photographs
- b. oblique photographs

**10.10 VERTICAL PHOTOGRAPHS**

A vertical air photograph is one that is taken with the optical axis of the camera perpendicular to the earth's surface. The camera is mounted in the aircraft to ensure this condition when the aircraft is in straight and level flight. In such photography ground features appear in plan view.

**10.11** Vertical air photos are usually printed with a certain amount of information included around the border which gives basic details of the area depicted. Whilst this detail varies depending on the agency which produced the photo the information usually includes the date the photograph was taken, the run number, the general area covered and the scale expressed as a fraction.

**10.12 OBLIQUE PHOTOGRAPHS**

Oblique air photographs are ones that are taken with the optical axis of the camera at an angle to the earth's surface. Depending on the acuteness of the angle such photographers are termed high or low obliques. These types of photographs are unlikely to be available in emergency operations and will not be described further.

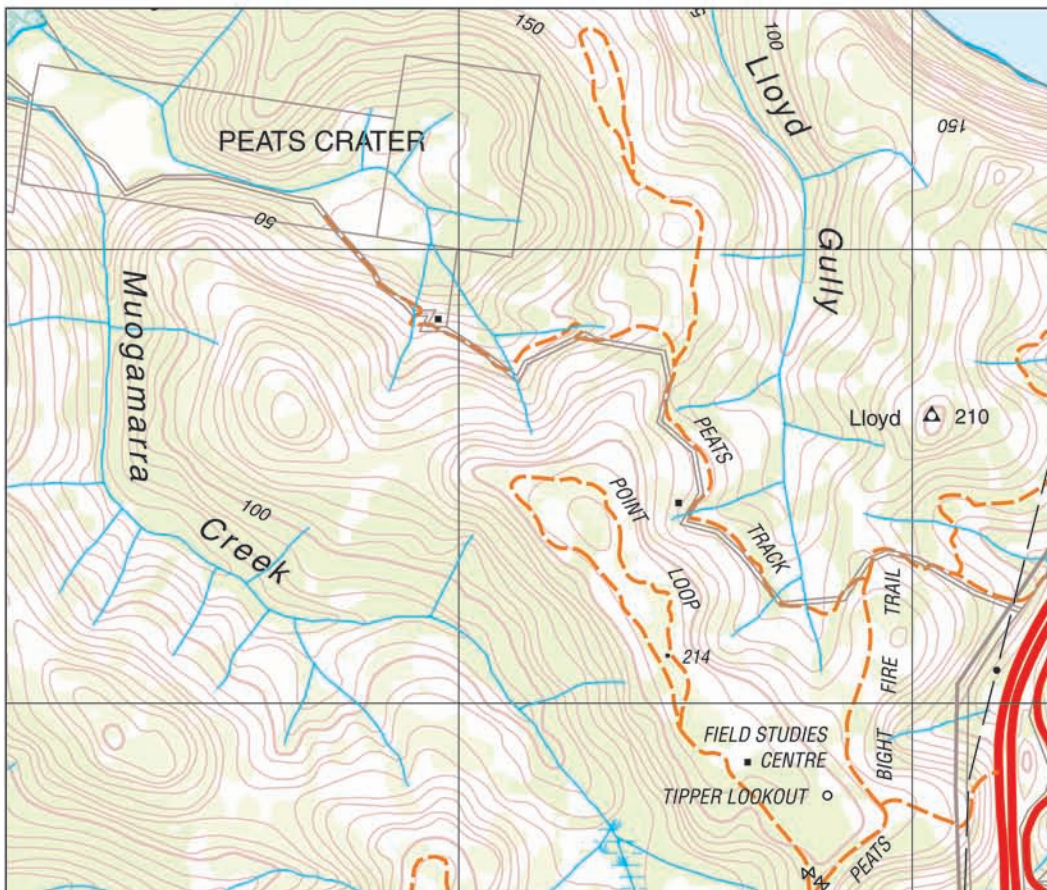
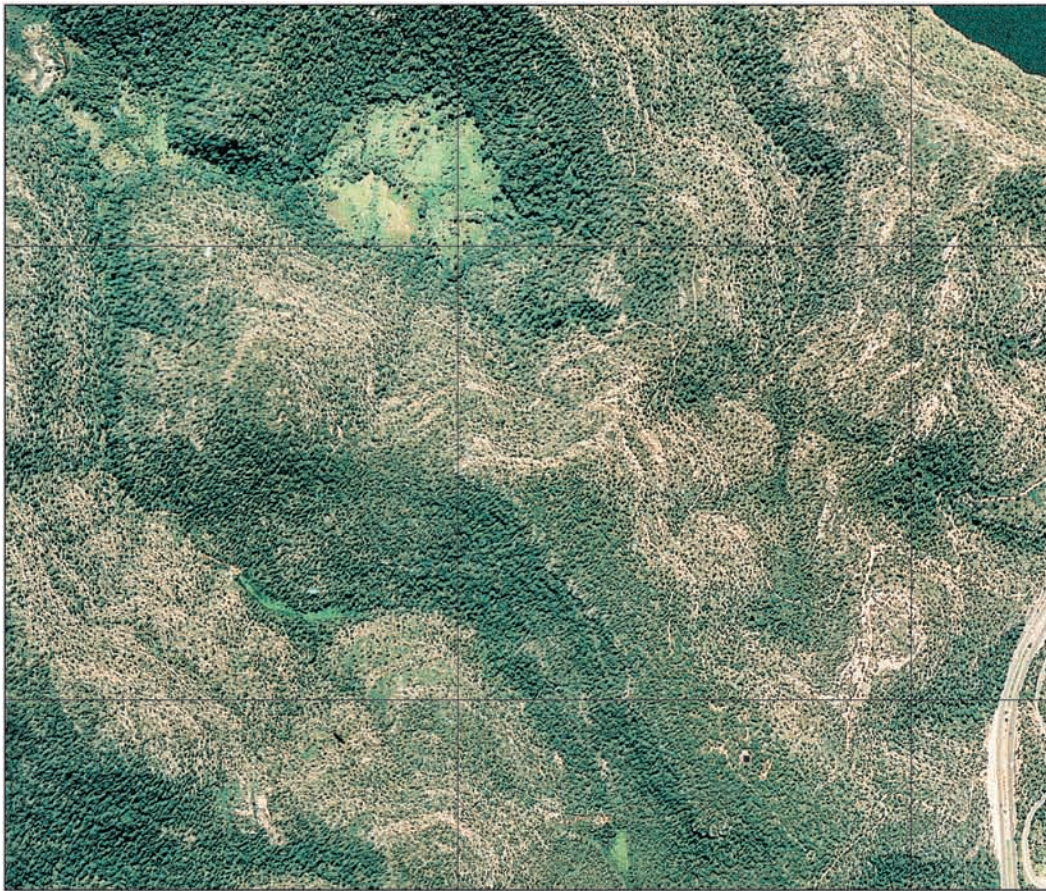

Figure 10-1: Vertical Air Photo and Map of the Same Area

## **STEREOSCOPY**

**10.13** Stereoscopy is the term applied to the science dealing with the appreciation of the third dimension, when two photographs of the same object, taken from different viewpoints are observed through certain optical instruments. The stereoscope is the optical instrument normally used to allow this appreciation of relief, and aids the recognition of objects.

### **10.14 STEREOVISION**

Stereovision is the ability to appreciate the third dimension. If we view an object with both eyes open we see the object from two slightly different view points simultaneously, each eye receiving a different picture. It is the fusing together of these slightly different pictures that enables us to see the object in full relief.

**10.15** It is possible to look at two photographs stereoscopically without using a stereoscope; however, if we do this the eyes automatically focus on the point at which the line of sight (of each eye) converge. Concentration on each photo side by side, will enable the viewer to focus without altering the line of sight. This is referred to as looking 'through' and not 'at' the photos.

### **10.16 THE STEREOSCOPE**

The most common way to achieve stereovision is to use a stereoscope to view a stereoscopic pair of air photos. Any two consecutive prints from a run can be used as a stereo pair; the normal 60 per cent overlaps ensuring that two views are available of most objects on the ground. If the stereo photographs are viewed, one with each eye, the brain combines to produce a picture in relief as in ordinary vision. The stereoscope helps us to look at and to focus two pictures separately but simultaneously, one with each eye, so that they can be seen in relief. The lens of the stereoscope usually magnify the photographs at the same time.

### **10.17 USING THE STEREOSCOPE**

Stereovision and the adjustment of a pair of photographs for stereo viewing will soon become automatic after some practice. In the early stages of training however, the following procedure will assist in orientation:

- a. Lay one print of a stereo pair over the other so that the detail of one print is directly over the corresponding detail of the other.
- b. Orient the photos so that the shadows fall towards you. (This is not essential but as shadows normally appear to fall 'downwards' this step is recommended).
- c. Select the object you wish to examine and pull the print apart until the images are a suitable distance apart. This distance will vary, but will usually be between 45 mm to 60 mm for most air photo readers.
- d. Place the stereoscope parallel to the line of flight and with each lens over one of the images.
- e. Look through the stereoscope and adjust the photos to bring the two images into one fused image. A third dimensional effect should then develop.



Figure 10-2: Use of the Stereoscope

## MOSAICS

**10.18** A mosaic is an assembly of overlapping photographs which have matched to form a continuous photographic representation of a section of the earth's surface.

### 10.19 TYPES OF MOSAICS

There are basically two types of mosaics:

- a. A mosaic consisting simply of overlapping runs of loose prints covering an area. Prints are trimmed at their overlapping edges and are either attached together by paper clips or pinned to suitable backing by pins.
- b. A mosaic consisting of a number of prints of an area cut to fit together and mounted on a suitable backing to form a composite whole. Marginal information is added to this mosaic.





# CHAPTER 11

---

## Latitude, Longitude System and Marine Charts

### INTRODUCTION

#### 11.1 MAP VARIATIONS

Maps used at sea and from the air differ considerably from those used to navigate on land. The major differences are:

- a. little information of land formations is given on them;
- b. they are not grided like most maps, but use a latitude, longitude system inscribed on the borders;
- c. different scales of measurement are used;
- d. different terms are used for like features ie soundings instead of heights; and
- e. a wide range of different symbols is used.

#### 11.2 MARINE NAVIGATION

Whilst this manual essentially deals with map reading and navigation on land there is a need for an understanding of some important marine terms. This need is due to the requirements to plot cyclones before they cross the coast, for plotting of vessels at sea and to assist with the location of aircraft downed on land. This section of the manual will therefore concentrate on the essential aspects of marine navigation sufficient to plot positions on marine maps or 'charts' as they are known.

### UNITS OF MEASURE

#### 11.3 MAIN SYSTEMS

Three main systems of measuring distance are in use in the world. These are 'the statute mile', 'the kilometre' and 'the nautical mile'. Whilst Australia has metricated weights and measures and therefore no longer uses 'statute' miles, maritime agencies continue to use the nautical mile and will do so for some time to come. The differences in these systems result from the way in which they are derived.

- a. **Statute Mile** – As the name implies, this unit of measure was set down by state in the reign of Queen Elizabeth I. It is sometimes called the 'empirical' scale. For standardisation it was set at '8 furlongs of 40 perches of 16.5 feet each' thus giving a total distance of 5280 feet per mile. These figures were arbitrarily chosen and bear no resemblance to any distance on the earth's surface.
- b. **Nautical Mile** – This is the unit used at sea and is approximately the distance in feet measured along a meridian, separating two places whose latitude differs by one minute. Because the earth is not an exact sphere this varies from the equator to the poles but is taken as an average of 6080 feet. The International Nautical Mile is 1852 metres.

- c. **Kilometre** – The definition of the measurement of the metre has varied over the years to obtain absolute accuracy. Originally it was supposed to be one ten millionth of the distance from the north pole to the equator.

#### 11.4 **KNOTS VS KILOMETRES PER HOUR**

For our purposes, the important role to note is the relative length of the nautical mile compared to the kilometre ie 1 nautical mile = 1.852 kilometres. Since a 'knot' is a speed of travel of one nautical mile per hour, 10 knots is ten nautical miles per hour or 18.52 kilometres per hour, a considerable size variation when plotting the progress of a cyclone. The two units therefore must not be confused or interposed one on the other.

#### 11.5 **OTHER TERMS OF NAUTICAL MEASUREMENT**

There are two further terms which may be encountered when talking to seafarers or using charts. Because they are not encountered on land maps they require some explanation:

- a. The Fathom – This is a measure of depth below surface of an object or line of the bottom. It is equivalent to 6 feet in the Imperial system or 1.83 metres.
- b. The Cable – This is a distance equivalent to one tenth of a nautical mile or 608 feet or 185.2 metres.

#### 11.6 **CONVERSION FACTORS**

When converting nautical miles or kilometres or knots to kilometres per hour the following conversion factors should be used:

Nautical miles or knots x 1.852 = kilometres or kilometres per hour

Kilometres/kilometres per hour x 0.54 = Nautical miles/knots

The conversion factors are important as the speed of travel of cyclones and the velocity of the wind associated with them is still frequently given in nautical miles or knots.

### **IDENTIFICATION OF LOCATIONS ON CHARTS**

- 11.7 Unlike maps, charts are not overlaid with a grid. They use a different system to identify a point on the surface of the earth based on its latitude and longitude. Scales for measurement are marked around borders of charts and unlike maps do not have a scale bar at the foot of the sheet.

#### 11.8 **MERIDIANS OF LONGITUDE**

These are lines on a chart which if extended would join at the poles. They are of the same length but the distance between them varies depending on whether the observer is near the equator or near one of the poles. They are also known as great circles. Their numbering is east or west of Greenwich in the UK, from 0 at Greenwich to 180° east or west at the opposite side of the globe, at what is known as the International Date Line.

**11.9 PARALLELS OF LATITUDE**

These are lines on a chart at right angles to meridians equally spaced and therefore parallel to each other. The equator is the zero reference line and parallels are numbered from zero to ninety at the north and south poles. Parallels differ in length depending on how far they are away from the equator.

**11.10 DEGREES, MINUTES AND SECONDS**

Degrees are the basis of describing a place on the surface of the earth and equating it to a position on a chart. Both parallels of latitude and meridians of longitude are stated in degrees indicated by the suffix ‘°’. Because this would not provide a sufficiently accurate location each degree is subdivided into 60 minutes; indicated by the suffix ‘’’, each minute further subdivided into 60 seconds; indicated by the suffix ‘”’. Latitude and longitude may also be expressed in degrees and decimal points of degrees. For emergency services’ purposes the use of seconds gives far greater accuracy than is required and can be ignored.

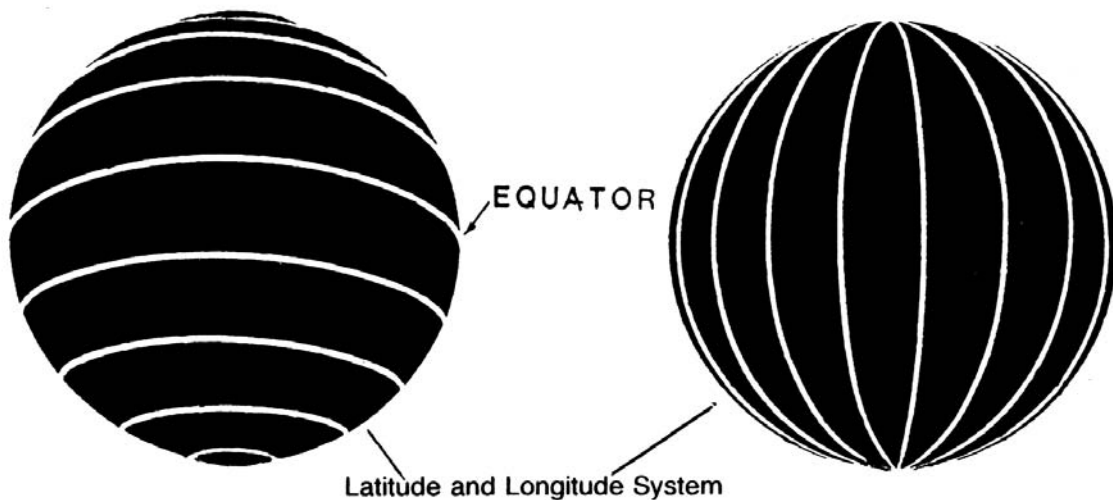

Figure 11-1: Latitude and Longitude System

**CONVENTIONS FOR STATING POSITIONS**

**11.11** When stating positions in the degrees, minutes and seconds format, the convention used is to give latitudes first then longitudes. Latitudes are given with a suffix either N (north) or S (south) depending on whether the position is north or south of the equator. This is followed by the longitude of the location and is suffixed E (east) or W (west) depending on whether the location is east or west of the Greenwich Meridian. As an example the general location of Perth is 31 degrees, 51 minutes, 0~ ‘seconds south, 115 degrees, 54 minutes, 0 seconds east; which would be written as:

Lat 31° 51’ 0” S Long 115° 54’ 0” E

**11.12 USE OF SECONDS**

It should be noted that the use of seconds as indicators of precise position would be rare. This is because one minute is equivalent to one nautical mile therefore one second is equivalent to one sixtieth of a nautical mile or 30.8 metres; a far greater accuracy than is necessary for plotting cyclones.

## MEASURING DISTANCES ON CHARTS

**11.13** Distance measurement on a grided map is a relatively simple process, each grid line is separated from the next by a representation of usually a distance one kilometre on the ground. This is true whether northing grid lines or easting grid lines are used. In addition all land map sheets have at the bottom margin, a scale for measuring distance. The same cannot be said for charts. Whilst the process of measuring distance on charts is not difficult a different system is used and certain rules must be applied.

### 11.14 MERCATOR PROJECTION

Because the world is a spheroid which we represent on a flat sheet of paper distortion is created no matter which form of projection is used. There are basically two types of projection used in charts the main one being 'Mercator'. On a Mercator chart parallels of latitude are shown as straight lines parallel to each other. The meridians are straight lines drawn at right angles to the parallels and are spaced equal distances apart. As the meridians on the earth's surface converge towards the poles, the above method of drawing the meridians, causes distortion of land masses in an east-west direction. To preserve the correct shape of the land, the parallels of latitude, which are equally spaced on the earth, are drawn in on the chart an increasing distance apart, as the latitude increases towards the poles.

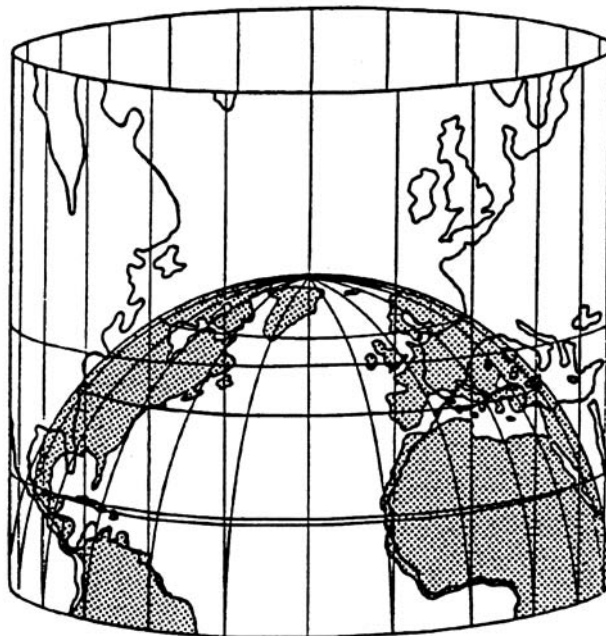

Figure 11-2: Mercator Projection

### 11.15 MEASURING PROCESS

The distance between the two points is measured using the latitude scale at the side of the chart. One minute of latitude is equal to 1~ ' nautical mile. Since each minute of latitude as marked on the chart gets progressively longer towards the poles, it is important that only that part of the latitude scale is used which lies abreast of the two points whose distances apart is required. The longitude scale at the top and bottom of edges is never used to measure distance but only to plot positions. A representation of the edge marking of various marine charts and the division of degrees, minutes and seconds is shown in Figure 11-3 below.

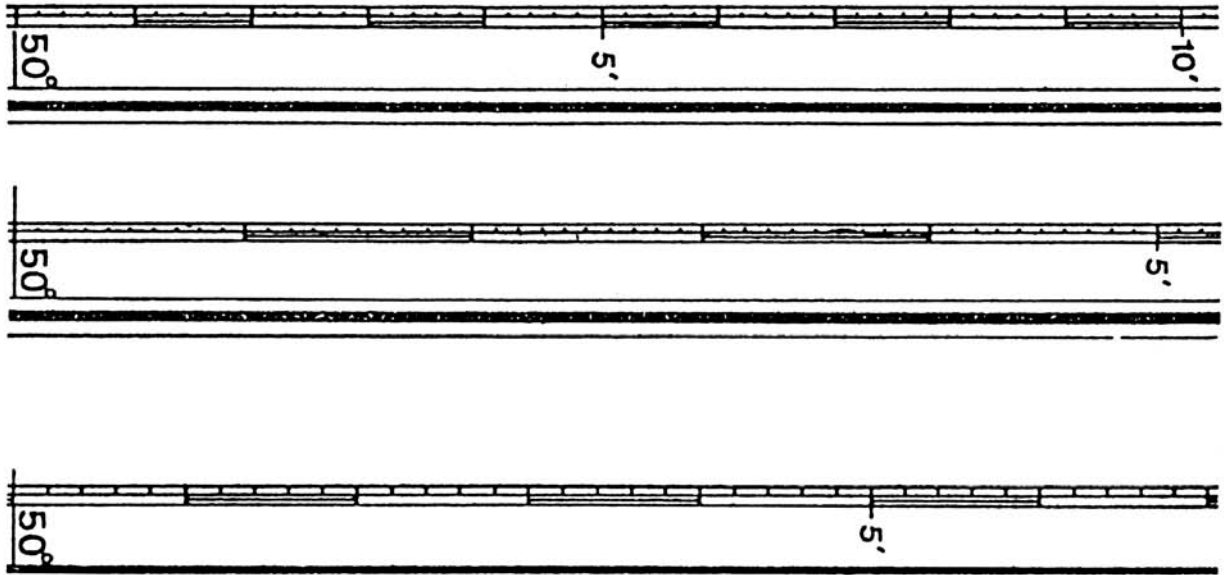

Figure 11-3: Methods of Graduating Latitude Scales on Marine Charts

**11.16 GNOMONIC PROJECTION**

Harbour charts, as well as those used for port approach, are drawn on gnomonic projection as are special charts for ocean navigation and polar regions. On a gnomonic chart, meridians which appear as straight lines converging to the poles and parallels of latitude, are curved. Because of the large scale of these charts, the convergence is generally so small that these charts may be used as any other map, and distances measured as with land maps.

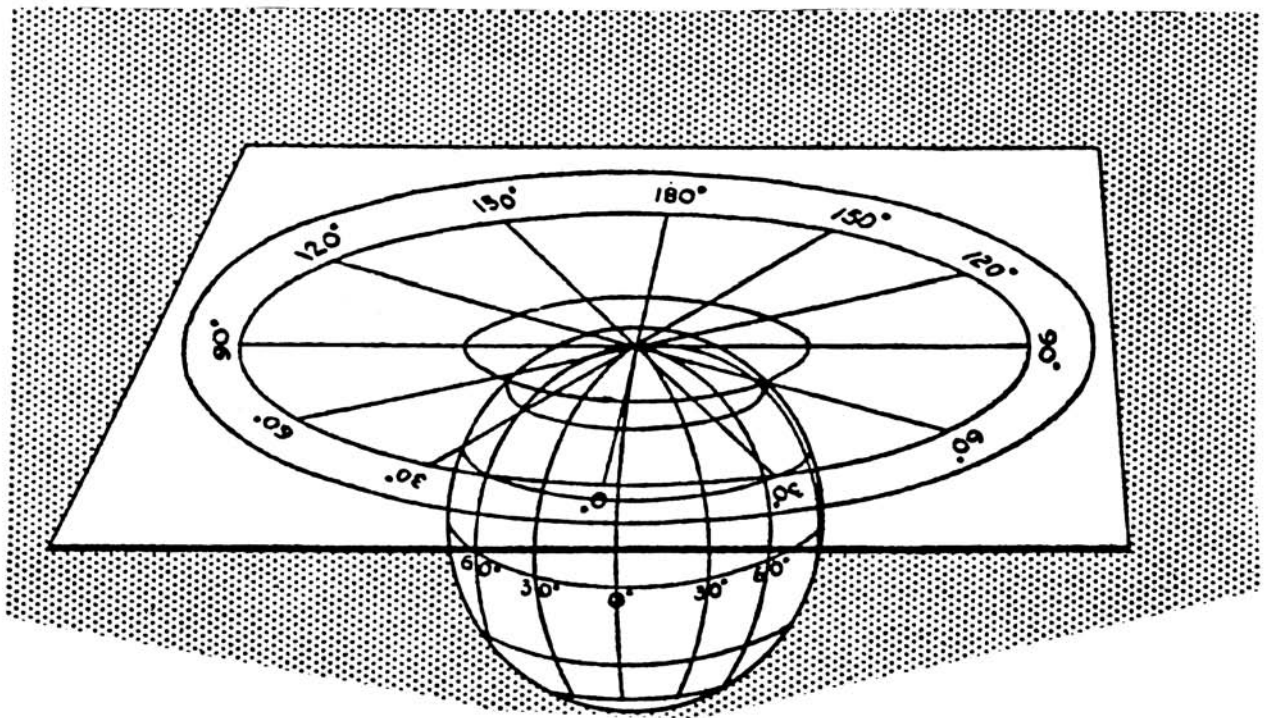

Figure 11-4: Gnomonic Projection

## **SUMMARY**

- 11.17** The preceding section provides information for a basic understanding of marine charts, the conventions of plotting and distance measurement are sufficient to plot cyclones, downed aircraft and ships at sea.

# CHAPTER 12

---

## Global Positioning System

### THE GLOBAL POSITIONING SYSTEM

- 12.1** The Global Positioning System (GPS) is a worldwide radio-navigation system formed from a constellation of 24 satellites and their ground stations. GPS uses these satellites as reference points to calculate positions accurate to a matter of metres. With advanced forms of GPS this accuracy can be made to better than a centimetre.
- 12.2** GPS receivers are generally hand held devices that assist with navigation on the ground, at sea, and in the air. The GPS receiver is only another aid to navigation and cannot be solely relied upon to navigate for you. It relies on the accuracy of the navigational data entered into the receiver.

### HOW GPS WORKS

- 12.3** The basis of GPS is triangulation from satellites. To triangulate, a GPS receiver measures distance using the time travel of radio signals. Using the signals from any three of these satellites, a two dimensional position is given, using any four satellites, a three dimensional, and therefore a very precise location of the GPS receiver is given.

### WHAT A GPS CAN DO

- 12.4** Some general functions of most GPS receivers are:
- a. determine ground speed;
  - b. plot current position;
  - c. store your current position as a waypoint;
  - d. store other positions as waypoints;
  - e. plot routes travelled;
  - f. calculate a bearing between two positions;
  - g. determine an error left or right of your intended track; and
  - h. determine a range or distance between two positions.
- 12.5** Many GPS receivers can perform a number of other navigational functions, some of which may include very accurate timing and elevation information.

### GPS NAVIGATION

- 12.6** Navigation with a GPS receiver is similar to navigating with a compass in that a map is used with both methods, and a clear understanding of the principles of map reading and navigation is essential.

- 12.7** As with the techniques explained in Chapter 9 of the manual, so are similar techniques used with GPS navigation. The principles of planning your intended route, studying the map, developing navigation data sheets etc still exist when using GPS receivers.

## **GPS PERFORMANCE AND LIMITATIONS**

- 12.8** Most GPS receivers need to have a clear, uninterrupted view of the sky to enable communication with the satellite constellation (network). Some conditions which may interfere with GPS performance are:
- a. cloud cover;
  - b. vegetation;
  - c. operating inside a building or in built-up area;
  - d. operating inside a motor vehicle without an external GPS antenna;
  - e. operating in gorges, caves, mines and other underground or low ground areas; and
  - f. they can be effected by electrical storms.
- 12.9** Most commercial GPS receivers are accurate to an average of 50 metres horizontally and 70 metres vertically. This accuracy is considered to be within the acceptable range for emergency services purposes.
- 12.10** Greater accuracy can be obtained by use of Differential GPS which relies on the use of dedicated ground monitor stations. This method is used for survey and military purposes only.
- 12.11** As GPS receivers are powered by batteries, it is important that the duration and the condition of the batteries is known, particularly before heading into rural or remote areas. Spare batteries should be carried, but as a backup to the GPS receiver, navigators should ensure that they have a magnetic compass and map with them at all times.

## **GRID COORDINATES**

- 12.12** GPS receivers are capable of displaying a position as either latitude and longitude, or as a grid reference. The universal grid reference system is used to display grid positions. To determine how to read four figure, six figure and eight figure grid references, refer to the Manufacturers Operations Manual.

## **MANUFACTURERS INSTRUCTIONS**

- 12.13** Users of GPS receivers should refer to the Manufacturers Instructions for the particular GPS receiver that they are using to determine the correct operating procedures and specific functions of the receiver.



# CHAPTER 13

---

## Geocentric Datum of Australia

### GEOCENTRIC DATUM OF AUSTRALIA

- 13.1** A 'Datum' is a mathematical surface on which a mapping and coordinate system is based. A 'geocentric datum' is a datum which has its origin at the Earth's centre of mass. The advantage of the geocentric datum is that it is directly compatible with satellite-based navigation systems.
- 13.2** Geocentric Datum of Australia (GDA) is replacing the Australian Geodetic Datum (ADG) which is based on a mathematical surface of the earth designed to fit the Australian region.

### BENEFITS

- 13.3** Adopting a geocentric datum allows for a single standard for collecting, storing and using geographic data. This will ensure compatibility across various geographic systems at the local, regional, national, and global level. A geocentric datum will also:
- provide direct compatibility with GPS measurements and mapping or Geographic Information Systems (GIS) which are based on the geocentric datum;
  - minimise the need for casual users to understand datum transformations;
  - allow more efficient use of organisations' spatial data resources by reducing the need for duplication and unnecessary translation; and
  - reduce the risk of confusion as GPS, GIS and navigation systems become more widely used in business and recreational activities.

### DIFFERENCES

- 13.4** GDA and AGD coordinates will vary by about 200 metres in a north-easterly direction because of the different models, with the GDA coordinates being those to the north-east. The actual size and orientation will vary slightly from place to place. It is important to note that both grid coordinates and latitude and longitude coordinates depend on the datum and both sets of coordinates will vary between datum. Therefore a feature on the ground will have different sets of geographical or grid coordinates, depending on the datum adopted.

The following diagram (Figure 13-1) shows an example of the difference between GDA and AGD.

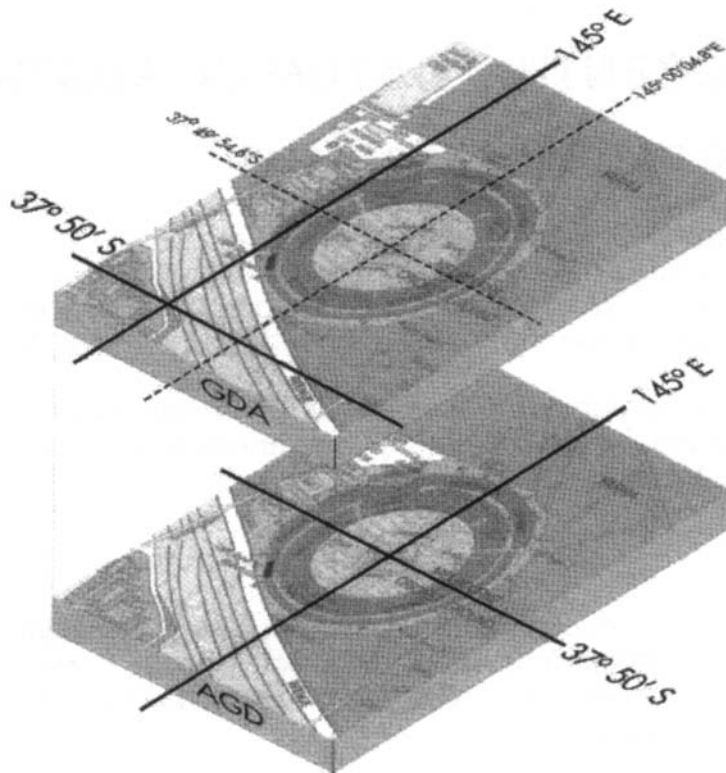

Figure 13-1: Difference Between GDA and AGD

**Note:** When using GPS units check the age of your map. AGD uses 1966 data whereas GDA uses 1994 data and is compatible with WGS 1984 and GPS units.

## IMPLICATIONS

- 13.5** Anyone using a map or a GPS receiver will need to know whether or not the grid and the latitude and longitude coordinates are given in AGD or GDA. This information will assist in accurately determining a route or a position on the map. As a rule of thumb, when converting from AGD to GDA your position will be approximately 200 metres north-east of where it is shown on a map. GDA maps can be identified by the GDA symbol as shown in Figure 13-2. People using a GPS receiver will need to check if it is using the AGD or the GDA coordinates.



Figure 13-2: GDA Symbol

# **CHAPTER 14**

---

## **Geographic Information Systems**

### **THE GEOGRAPHIC INFORMATION SYSTEM**

- 14.1** A Geographic Information System (GIS) is a system for capturing, storing, checking, manipulating, analysing and displaying data which is spatially referenced to the earth.
- 14.2** The GIS can be seen as an electronic map where key features are referenced from a number of databases and which are then displayed in graphical format. This information can then be manipulated to display a choice of appropriate themes.
- 14.3** GIS can be used by emergency managers to provide critical information, for example:
- a. providing an incidence map and thematic map during the hazard analysis phase;
  - b. evacuation routing during the prediction and warning phase;
  - c. damage incident reporting and emergency vehicle routing during the response phase; and
  - d. damage assessment and project monitoring during the recovery phase.
- 14.4** Additional information on the uses of GIS can be found in appropriate text books and from suppliers of GIS products. Uses for GIS by emergency managers and responders will develop as their understanding of the system increases.



# GLOSSARY

---

**Basin**

An area of reasonably level ground, surrounded or nearly surrounded by hills.

**Cartographer**

A technician who compiles and draws maps/charts.

**Chart**

The term applied to maps used for sea and air navigation.

**Col**

*See Saddle.*

**Crest**

The highest part of a hill or mountain range.

**Cultural features**

Structures and agricultural or other purpose planted vegetation, which has been created by humans and is represented on the map.

**Declination**

*See Magnetic variation.*

**Eastings**

The vertical grid lines on a map, which run from the bottom to the top and are numbered from west to east.

**Gorge**

A deep ravine, usually with steep, precipitous sides.

**GPS**

Acronym for global positioning system, which is a navigational aid, consisting of a ground receiver and a series of satellite transmitters.

**Isogonals**

Lines which join places of equal magnetic variation on the earth's surface.

**Knoll**

A small knob-like hill.

**Lubber line**

(Also Lubber's line) is the static mark on the body of the compass, which designates the centre line axis of the compass housing.

**Magnetic variation**

The angle between magnetic north on the compass and grid north on the map.

**Marginal information**

Additional information contained in the margin of a topographic map which is essential to its operational use.

**Meridians of longitude**

Lines on a chart which, if extended, would join at the poles.

**Natural features**

Land forms and vegetation which occurs naturally on the ground and is represented on the map.

**Northings**

The horizontal grid lines on a map, which run from left to right and are numbered from south to north.

**Oblique photograph**

An aerial photograph, taken with optical axis of the camera at an angle to the earth's surface.

**Orienteering**

A sport where competitors follow a designated course to given checkpoints, with the aid of a map and compass.

**Parallels of latitude**

Lines on a chart at right angles to the meridians, equally spaced and are parallel to each other.

**Prism**

A three sided polygonal transparent lens, fitted to a compass to enable the sighting of bearings.

**Plateau**

A generally level, elevated region of considerable extent.

**Ravine**

A long, deep and steep valley, gouged in the earth by a stream.

**Re-entrant**

A valley or ravine, running inwards towards a hill or mountain top, usually between two spurs.

**Resection**

A method of using compass bearings to accurately measuring a point within a grid square.

**Saddle**

The depression in the ground between two adjacent hills or mountain tops.

**Scale**

The scale of a map is the relation of the horizontal distances between two points measured on the ground and the same two points measured on the map.

**Sounding**

The process of measuring and recording the depth of water.

**Spatial data**

Is the data pertaining to the locational aspect of geographical features, together with their spatial dimensions.

**Spur**

A ridge which runs out from a hill or mountain range.

**Stereoscope**

An instrument used to obtain relief effect when reading aerial photographs.

**Topography**

The detailed mapping of the land forms or surface configuration of a region. This information is used to produce a topographic map.

**Undulating ground**

Ground which gently rises and falls away.

**Vertical photograph**

An aerial photograph, taken with the optical axis of the camera perpendicular to the earth's surface.



[www.ema.gov.au](http://www.ema.gov.au)